

IAQ ENFORCER™ Installation Guide

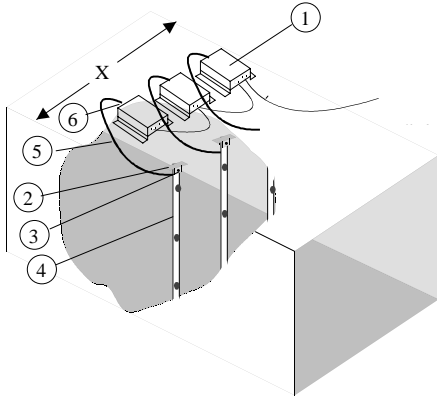

1. PHYSICAL INSTALLATION

1.1 PRE INSTALLATION CHECKS

1.11 - All EBTRON T00P Model Systems are 100% factory assembled, tested, and calibrated prior to shipment. Proper application and installation are necessary to achieve the maximum benefit and the unmatched performance from the EBTRON System.

1.12 - Inspect for Possible Shipping Damage

1.13 - Upon arrival, all packages should be visually inspected for obvious damage to its exterior. It is YOUR responsibility to note any obvious damage on the Bill of Lading, and make the claim on the carrier.

1.14 - It is EBTRON's recommendation not to unpack the equipment, until shortly before the unit is to be installed. This procedure will help prevent any damage due to handling or storage at the site.

1.15 - Evaluate Duct Placement. The locations selected for the installation of EBTRON systems are critical to the proper function of the unit. Locations should be selected by the engineering authority for the project. Please refer to EBTRON's engineering design catalog for more information.

1.16 - **Match Components Before Physical Installation.** The T00P Model EBTRON is a two-part system, consisting of (1) a sensor probe(s), and (2) a separate microprocessor and electronics panel (enclosure). The probe is manufactured to the specific size of the duct and should not be installed in a duct with dimensions different than those for which it was ordered. The two-part system is factory calibrated as a single unit and are unique to each other. **THE SERIAL NUMBERS ON THE PROBE MUST MATCH THE SERIAL NUMBER ON THE ELECTRONICS PANEL. FAILURE TO MATCH THESE SERIAL NUMBERS WILL RESULT IN ERRONEOUS OUTPUT AND POSSIBLE DAMAGE TO THE UNIT.**

1.2 RECTANGULAR DUCTS AND PLENUMS

1.21 - Each package is labeled for serial number, duct size and location. Multiple probe systems are shipped in separate packages. Averaging panels for multiple units are packaged with the probe labeled "Averager Inside". Carefully open

packages and inspect for damage.

1.22 - Locate the position on the duct indicated by the engineers plans where the temperature measuring station (TMS) is to be located. Caution: Proper location of the flow station is critical for optimal sensor performance.

1.23 - Place a carpenter's square along the inside edge of the duct (or plenum wall) which the probe will be mounted in. Mark a line perpendicular to the edge of the duct, perpendicular to flow, so that it traverses the distance "X" on in the figure to the left. This line will be used to locate the position of the center line for the mounting feet of each probe.

1.24 - Repeat Step 1.23 directly across from where you marked the line for the probe to be mounted.

1.25 - Refer to Table 1 to determine the location of the mounting holes from the edge of the duct (free area dimensions). Mark each position on the line drawn in steps 1.23 and 1.24.

1.26 Each Model T00P probe assembly has a connecting cable permanently attached to the sensor probe. Make sure that the probe is oriented so that the connecting cable is properly positioned for connection to the electronics panel.

TABLE 1 - Location of Probe Centers

Number of Probes	Distance From Edge of Duct			
	Probe 1	Probe 2	Probe 3	Probe 4
1	0.500 X			
2	0.250 X	0.750 X		
3	0.167 X	0.500 X	0.833 X	
4	0.125 X	0.375 X	0.625 X	0.875 X

X=Inside Duct Dimension Perpendicular to Probe

1.27 - Place the first sensor probe (for consistency use the lowest serial number first) at the location marked for position 1 from step 1.25, above.

1.28 - The two mounting holes on the mounting bracket foot should be placed over the line marked in step 1.23. The center line of the probe should intersect the mark for probe 1 in step 1.25. Using suitable hardware for duct mounted accessories, secure the mounting bracket to the duct.

1.29 - Follow step 1.28 for the mounting bracket located at the opposite end of the probe for the line marked in step 1.24.

1.30 - Mount the electronics panel for each probe (**THE SERIAL NUMBERS ON THE PROBE MUST MATCH THE SERIAL NUMBER ON THE ELECTRONICS PANEL**) at a convenient location within reach of the connecting cable from the probe.

1.31 - Connect the twist-lock circular connector from the Model T00P probe to the electronics panel. The connector is keyed for proper connection.

2. ELECTRICAL CONNECTION BETWEEN SATELLITE STATION AND SENSOR PROBE

2.1 ALL MODELS EXCEPT T21P AND T22P

2.11 - Connect the single twist-lock connector from the sensor probe to the remote electronics panel. **THE SERIAL NUMBER ON THE PROBE MUST MATCH THE SERIAL NUMBER ON THE ELECTRONICS PANEL. FAILURE TO MATCH THESE SERIAL NUMBERS WILL RESULT IN ERRONEOUS OUTPUT AND POSSIBLE DAMAGE TO THE UNIT.**

2.2 MODELS T21P AND T22P

2.21 - Each of the sensor probes is color coded. Connect the

color coded twist-lock connector to the same color coded receptacle on the electronics panel. **THE SERIAL NUMBERS ON THE PROBES MUST MATCH THE SERIAL NUMBER ON THE ELECTRONICS PANEL. FAILURE TO MATCH THESE SERIAL NUMBERS WILL RESULT IN ERRONEOUS OUTPUT AND POSSIBLE DAMAGE TO THE UNIT.**

3. ELECTRICAL CONNECTIONS TO SIGNAL PROCESSORS

- SEE APPROPRIATE SIGNAL PROCESSOR INSTRUCTIONS