

## -P Probe Installation (Insertion Mounting - Rectangular Ducts)

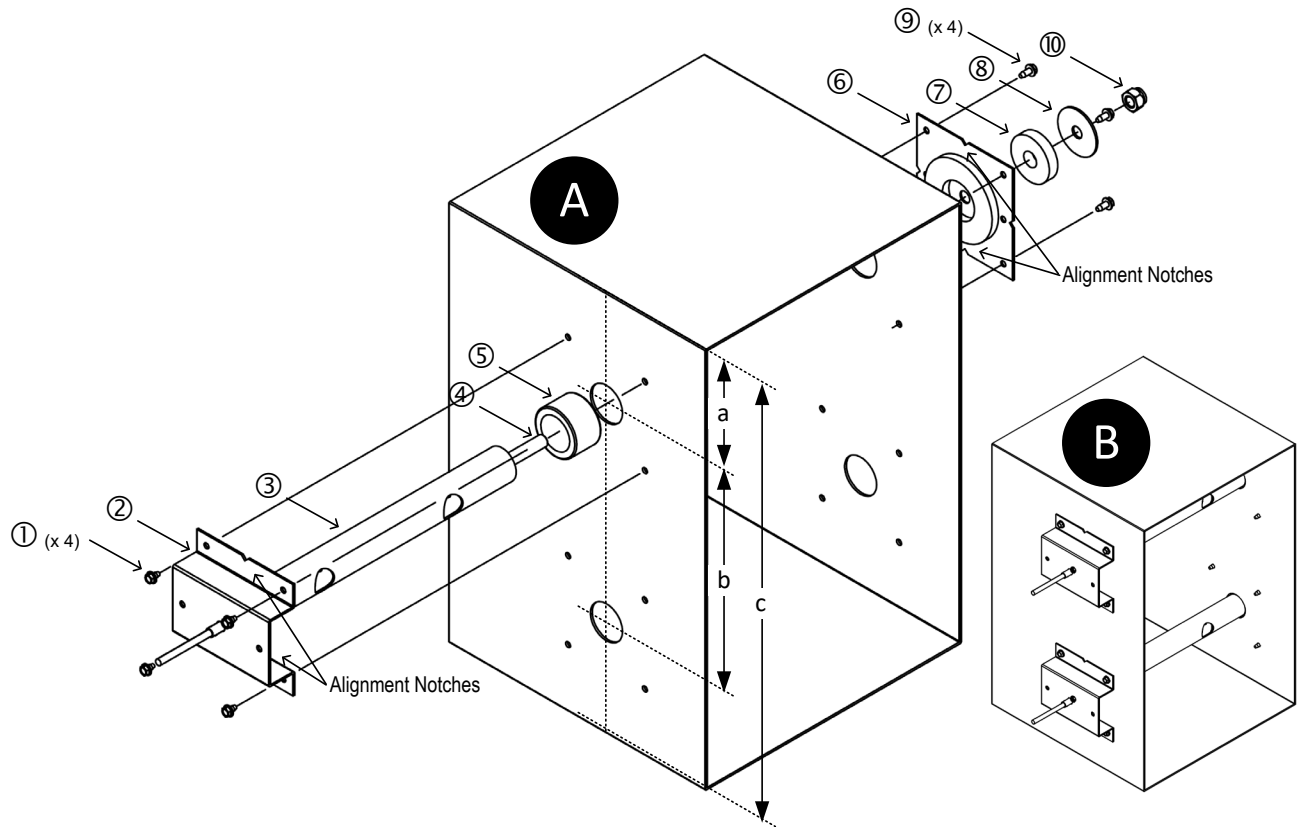

Step 1. Select a location in the duct or plenum opening that meets or exceeds EBTRON's recommended placement guidelines.



*If the location does not meet or exceed placement guidelines the installed accuracy may be compromised and field adjustment may be necessary.*



*For Gold Series, install sensor probes at location (if provided) indicated on probe hang tag to optimize implementation of the EB-Link Reader and IAQ Enforcer accessories.*

Step 2. Probes are ordered and labeled *Probe Length x Adjacent Side Length*. Probes are installed through the *Adjacent Side* dimension, 'c', of the duct. Verify that the duct size matches the size ordered.



*If the probe length ordered is incorrect, the sensors will not be located in the proper location, thus affecting the installed accuracy. Contact EBTRON customer service for more information.*



*If the actual size of the duct is not equal to the size ordered, the AREA parameter must be changed in the transmitter to display the proper airflow rate in CFM [l/s].*



*Do not cut the probe! Cutting the probe will void warranty.*

REFER TO FIGURE "A" WHEN COMPLETING STEPS 3 TO 22.

Step 3. Vertically mounted probes subject to water condensation or accumulation (typically supply air and outdoor air intakes) should be mounted so that the cable side of the probe is at the top of the duct.

Step 4. Draw a line on the outside of the duct side chosen as the insertion side that is perpendicular to the edge of the duct and the direction of airflow.



*Use a carpenter's square or similar tool to ensure the probes are in the same plane and perpendicular to airflow.*

- Step 5. Mark a center-point on the line drawn in Step 4 where each probe is located using the spacing guidelines indicated in Table 1. If more than two probes are provided, continue spacing additional probes at the 'b' interval from the previous probe.

TABLE 1 - PROBE PLACEMENT		
Number of Probes	a	b
1	c/2	
2	c/4	c/2
3	c/6	c/3
4	c/8	c/4



*If the probes were ordered for a duct with internal insulation, use the internal dimension of the duct for 'c' to calculate 'a' and 'b', then add the internal insulation thickness to 'a'.*

- Step 6. Use the terminal mounting plate [6] as a template to locate the position for the four insertion mounting bracket screws [1]. Position the terminal mounting plate [6] on the duct with the foam gasket pointing away from the duct so that the center-point marked in Step 5 is in the center of the center-hole of the terminal mounting plate [6]. Position the terminal mounting plate [6] so that the center-line notches of the plate are aligned with the line drawn in Step 4. Mark the location of the four insertion mounting bracket screws [1] that secure each insertion mounting bracket [2]. Repeat this step for each additional probe center-point, if more than one probe is provided.



*Probes less than 18 inches do not have a terminal mounting plate [6]. Remove the large foam gasket [5] from the probe tube [3] and insert a probe into the duct after completing step 7. Use the probe mounting bracket [2] as a template to mark the location for the four mounting screws [1]. Use the alignment notches on the probe mounting bracket [2] to ensure proper alignment in the duct.*

- Step 7. Drill a 1-1/8 inch hole at each probe center-point marked in Step 5.
- Step 8. Drill appropriately sized pilot holes for each insertion mounting bracket screw [1] location (screws not provided) marked in Step 6.
- Step 9. If the probes are provided with the terminal mounting plate [6], follow Steps 10 to 14, otherwise skip to Step 15.
- Step 10. On the opposite side of the duct, mark a line perpendicular to the edge of the duct and the direction of airflow directly across from the line marked in Step 4.
- Step 11. Mark a center-point on the line drawn in Step 10 directly across from each center-point marked in Step 5.
- Step 12. Use the terminal mounting plate [6] as a template to locate the position for the four terminal mounting plate screws [9]. Position the terminal mounting plate [6] on the duct with the foam gasket pointing away from the duct so that the first center-point marked in Step 11 is in the center of the center-hole of the terminal mounting plate [6]. Rotate the terminal mounting plate [6] so that the center-line notches of the plate are aligned with the line drawn in Step 10. Mark the location of the four terminal mounting plate screws [9] that secure each terminal mounting plate [6]. Repeat this step for each additional probe center-point, if more than one probe is provided, using the center-point(s) created in Step 11.
- Step 13. Drill a 1-1/8 inch hole at each probe center-point marked in Step 11.



*Drilling the larger mounting hole, in lieu of a hole the size of the terminal mounting bolt, facilitates installation of longer probes.*

Step 14. Drill appropriately sized pilot holes for each terminal mounting plate screw location (screws not provided) marked in Step 12.

Step 15. Make sure the large foam gasket [⑤] is installed on each probe tube [③] against the insertion mounting bracket [②].



*Probes are labeled Probe X of Y, where Y is the total number of probes provided for a location. It is recommended (not required) that probes are installed sequentially by probe number top to bottom, left to right or vice versa.*

Step 16. Follow steps 17 to 22 for each probe.

Step 17. Insert the probe tube [③] in the duct with the airflow directional arrow pointing in the direction of airflow (it is ok if the arrow is upside down).

Step 18. Secure the insertion mounting bracket [②] to the duct with the four mounting screws [①] selected.

Step 19. If the probes are provided with the terminal mounting bracket [⑥], follow Steps 20 to 22, otherwise skip to Step 23.

Step 20. Place the terminal mounting plate [⑥] over the terminal mounting bolt [④] of the probe and secure the terminal mounting plate [⑥] to the duct with the four mounting screws [⑨] selected. The foam gasket on the plate should be facing the duct.

Step 21. Place the small foam gasket [⑦], large fender washer [⑧] and lock nut [⑩] on the terminal mounting bolt [④].

Step 22. Tighten the lock nut [⑩] until the small foam gasket [⑦] is compressed to approximately 50% of its original thickness.

Step 23. Probe installation is complete! Figure “B” shows a completed two probe installation.