

IAQ ENFORCER™ Installation Guide

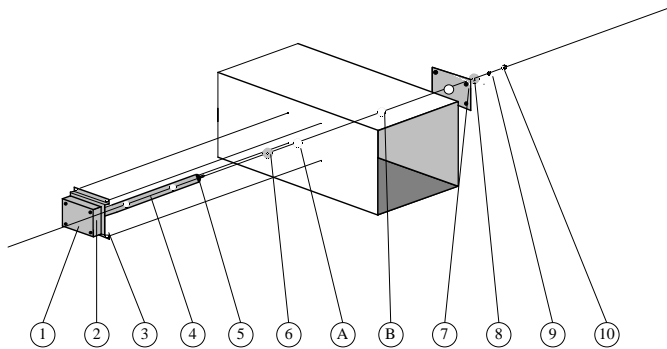

1. PHYSICAL INSTALLATION

1.1 ALL DUCTS

1.11 - Each package is labeled for serial number, duct size and location. Multiple probe ducts are shipped in separate packages. The Central Station Panel for the IAQ Enforcer contains the wiring schematic and system configuration. Carefully open packages and inspect for damage.

1.12 - Locate the position on the duct indicated by the engineers plans where the air flow measuring station (AFMS) is to be located. Caution: Proper location of the flow station is critical for optimal sensor performance.

1.2 RECTANGULAR DUCTS

1.21 - Place a carpenters square along the edge of the duct which the probe will be inserted through. Mark a line perpendicular to the edge of the duct, perpendicular to flow, so that it traverses the distance "X" on in the figure above. This line will be used to locate the position of the holes which need to be drilled for probe insertion.

1.22 - If the probes are greater than 18" they will have a terminal mounting bolt [5] protruding out of the side of the probe opposite the mounting bracket [3]. Repeat Step 3 directly across from where you marked the line for the probe to be inserted. If they do not have a terminal mounting bolt, ignore this step and any references to mounting hole B.

1.23 - Refer to Table 1 to determine the location of the mounting holes from the edge of the duct (free area dimensions, add for insulation). Skip to step 1.4 - ALL DUCTS

1.3 ROUND DUCTS

TABLE 1 - Location of Mounting Holes on Rectangular Duct Systems

Number of Probes	Distance From Edge of Duct*			
	Probe 1	Probe 2	Probe 3	Probe 4
1	0.500 X			
2	0.250 X	0.750 X		
3	0.167 X	0.500 X	0.833 X	
4	0.125 X	0.375 X	0.625 X	0.875 X

X=Inside Duct Dimension of Insertion Side

* Add internal insulation to distance calculated

1.31 - Locate a point on the duct where the first probe will be inserted. Measuring along the curved surface, mark points away from the origin as calculated from the values in Table 2. If the duct is greater than 18" in diameter, mark both the insertion and terminal positions, otherwise, mark only the insertion side.

TABLE 2 - Location of Mounting Holes on Round Duct Systems

Number of Probes	Distance along Duct Circumference				
	Side	Probe 1	Probe 2	Probe 3	Probe 4
1	Insertion	Origin			
	Terminal	1.571 X			
2	Insertion	Origin	0.785 X		
	Terminal	1.571 X	2.356 X		
3	Insertion	Origin	0.524 X	1.047 X	
	Terminal	1.571 X	2.094 X	2.618 X	
4	Insertion	Origin	0.392 X	0.785 X	1.178 X
	Terminal	1.571 X	1.963 X	2.356 X	2.749 X

X=Outside Diameter of Duct

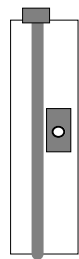

1.32 - Each of the probes need to be staggered from one another since they each go through the center of the duct. Refer to the figure at the right to view a typical installation for a two probe system. Skip to step 1.4 - ALL DUCTS.

1.4 ALL DUCTS

1.41 - Using a 1 1/8 to 1 3/8 inch diameter drill, drill holes A and B where indicated

1.42 - Place the probe assembly [4] through mounting hole A making sure that gasket [6] is firmly against mounting plate [3]. Fasten mounting plate [3] to duct with appropriate sheet metal screws making sure that the edge of the plate which mounts to the duct is as parallel as possible to the edge of the duct and the direction of flow.

1.43 - If probe assembly has a terminal mounting bolt [5] then follow steps 1.44 through 1.46 ,otherwise jump to section 2. WIRING.

1.44 - Place terminal mounting bracket [7] onto terminal bolt [5] which should now be protruding out the opposite side of the duct. Fasten mounting plate [7] to duct with appropriate sheet metal screws.

1.45 - Place foam shock absorber/gasket over terminal mounting bolt [5] then place washer [9] against shock absorber.

1.46 - Tighten lock nut [10] onto terminal mounting bolt until snug. A tight fit is not required and will allow for duct movement when pressurized.

2. ELECTRICAL CONNECTIONS

- SEE APPROPRIATE SIGNAL PROCESSOR INSTRUCTIONS