

IAQ ENFORCER™ Installation Instructions

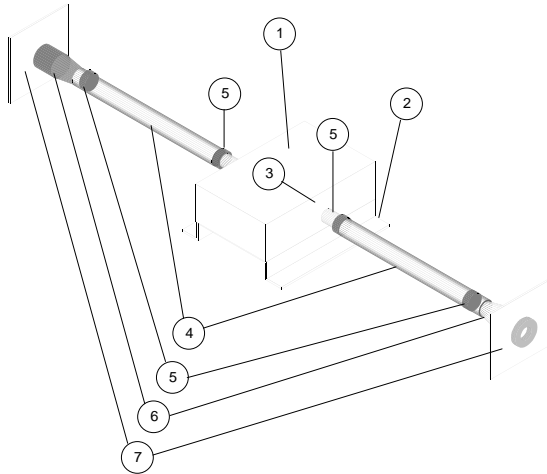

1. PHYSICAL INSTALLATION

1.1 ALL SYSTEMS

1.11 - Each package is labeled for serial number, duct size and location. Carefully open packages and inspect for damage.

1.12 - Locate the position on the duct, wall or ceiling indicated by the engineers plans where the sensor system is to be located. Caution: Proper location of the flow station is critical for optimal sensor performance.

1.2 ACROSS DUCTED DAMPERS

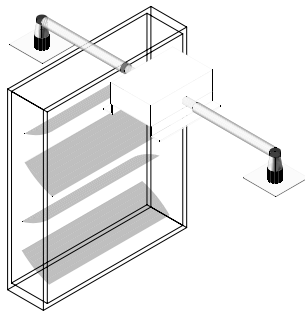

1.21 - The terminal barbed fittings [6] for this mounting should be two 90 degree fittings. Contact Ebtron customer service if the units were ordered with the incorrect barbed fittings.

1.22 - In the center of the duct, mount the electronics pack approximately 4 inches upstream or downstream of the damper using suitable hardware so that the barbed sensor fittings are parallel to the duct wall. For environmental reasons, it is generally desirable to mount the electronics pack downstream (opposite of the intake louver side) of outside air intake dampers or upstream (opposite of the relief louver side) on relief air dampers. **Although the sensor is bidirectional, the unit must be installed in the proper orientation. For outside air dampers, the airflow arrow should face away from the outside air intake louver. For relief air dampers, the airflow arrow should face towards the relief louver.**

1.23 - Mark a location in the center of the duct upstream and downstream of the damper, at least 4 inches away from the damper, that allows for the terminal barbed fittings and mounting plates [6] & [7] to be installed and the reinforced

tubing [4] to be installed on the sensor [3] and the barbed fitting [6].

1.24 - Using a 2" hole saw, drill the up and downstream holes

1.25 - Place the terminal plate over the upstream 2" hole so that the protruding end of the terminal barbed fitting opposite the barbed end is in the center of the 2" hole. With the barbed fitting facing the electronics pack, measure the distance between the sensor barbed fitting and the terminal barbed fitting to determine the length that the connecting tube must be cut to slip completely over each barbed fitting. Cut the reinforced tubing to length.

1.26 - Place the stainless steel hose clamps [5] over each end of the cut tubing. Slip the hose over the sensor barb, being careful not to damage the sensor. Applying a thin film of soap to the sensor barb may ease the process. Slip the hose over the terminal barbed fitting. **DO NOT TIGHTEN THE HOSE CLAMPS AT THIS TIME.**

1.27 - Apply a sealer to the terminal plate opposite the barbed end of the terminal fitting and fasten the plate to the duct so that the protruding end of the terminal barbed fitting opposite the barbed end is in the center of the 2" hole that has been drilled into the duct system.

1.28 - Straighten the tube, assuring that there are no twists, bends or kinks. Tighten the hose clamps. **DO NOT OVER TIGHTEN THE CLAMPS.**

1.29 - Follow steps 1.25 through 1.28 for the downstream location.

1.3 BETWEEN WALLS AND CEILINGS (also applicable to unducted plenum dampers)

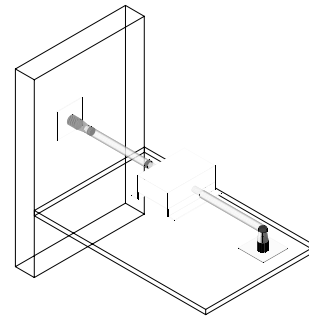

1.31 - The terminal barbed fittings [6] for this mounting should be one 90 degree fitting and one straight fitting. Contact Ebtron customer service if the units were ordered with the incorrect barbed fittings.

1.32 - Mount the electronics pack approximately 6 inches away from the wall on a ceiling or plate using suitable hardware. **Orient the electronics so that the airflow arrow faces away from the positive pressure source** and is perpendicular to the wall (for unducted plenum dampers see the bold print in section 1.12).

1.33 - Mark a location on the wall 2 inches above the ceiling directly across from the barbed sensor fitting. Mark a second hole, 6 to 12 inches away from the opposite barbed sensor fitting.

1.34 - Using a 2" hole saw, drill a hole in the wall and ceiling

that were marked in step 1.33.

1.35 - Place the terminal plate over the wall 2" hole so that the protruding end of the terminal barbed fitting opposite the barbed end is in the center of the 2" hole. With the barbed fitting facing the electronics pack, measure the distance between the sensor barbed fitting and the terminal barbed fitting to determine the length that the connecting tube must be cut to slip completely over each barbed fitting. If the plate is going to be mounted on the opposite side of the wall (or ceiling), add an additional length to the cut length for the tube. Cut the reinforced tubing to length.

1.36 - Place the stainless steel hose clamps [5] over each end of the cut tubing. Slip the hose over the sensor barb, being careful not to damage the sensor. Applying a thin film of soap to the sensor barb may ease the process. If the terminal plate is going to be mounted on the same side of the wall (or ceiling) as the electronics pack, slip the hose over the terminal barbed fitting, otherwise complete step 1.37 before attaching the hose to the terminal barbed fitting. **DO NOT TIGHTEN THE HOSE CLAMPS AT THIS TIME.**

1.37 - Apply a sealer to the terminal plate and fasten the plate to the wall so that the protruding end of the terminal barbed fitting is not obstructed into the space on the opposite side of the wall.

1.38 - Straighten the tube, assuring that there are no twists, bends or kinks. Tighten the hose clamps. **DO NOT OVER TIGHTEN THE CLAMPS.**

1.39 - Follow steps 1.35 through 1.38 for the ceiling location.

1.4 BETWEEN TWO WALLS

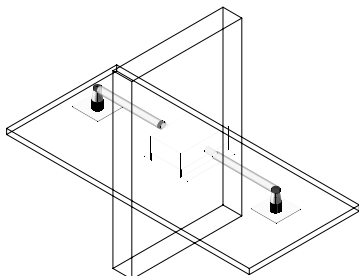

1.41 - The terminal barbed fittings [6] for this mounting should be two 90 degree fittings. Contact Ebtron customer service if the units were ordered with the incorrect barbed fittings.

1.42 - Mount the electronics pack approximately 6 inches away from the wall on a ceiling or plate using suitable hardware.

Orient the electronics so that the airflow arrow faces away from the positive pressure source and is perpendicular to the wall.

1.43 - Mark a location on the wall 2 inches above the ceiling directly across from the barbed sensor fitting. Mark a second hole, 6 to 12 inches away from the opposite barbed sensor fitting. On the opposite side of the wall, mark a third hole 6 to 12 inches directly across from the hole that was marked in the wall.

1.44 - Using a 2" hole saw, drill a hole in the wall and the two ceilings that were marked in step 1.33.

1.45 - Place the terminal plate over the one ceiling 2" hole so that the protruding end of the terminal barbed fitting opposite the barbed end is in the center of the 2" hole. With the barbed fitting facing the electronics pack, measure the distance

between the sensor barbed fitting and the terminal barbed fitting to determine the length that the connecting tube must be cut to slip completely over each barbed fitting. If the plate is going to be mounted on the opposite side of ceiling, add an additional length to the cut length for the tube. Cut the reinforced tubing to length.

1.46 - Place the stainless steel hose clamps [5] over each end of the cut tubing. Slip the hose over the sensor barb, being careful not to damage the sensor. Applying a thin film of soap to the sensor barb may ease the process. If the terminal plate is going to be mounted on the same side of the wall or ceiling as the electronics pack, slip the hose over the terminal barbed fitting, otherwise complete step 1.47 before attaching the hose to the terminal barbed fitting. **DO NOT TIGHTEN THE HOSE CLAMPS AT THIS TIME.**

1.47 - Apply a sealer to the terminal plate and fasten the plate to the wall so that the protruding end of the terminal barbed fitting is not obstructed into the space on the opposite side of the wall.

1.48 - Straighten the tube, assuring that there are no twists, bends or kinks. Tighten the hose clamps. **DO NOT OVER TIGHTEN THE CLAMPS.**

1.49 - Follow steps 1.45 through 1.48 for the other ceiling location.

2. FIELD WIRING

- SEE APPROPRIATE SIGNAL PROCESSOR INSTRUCTIONS