

the Eliminator™ Installation Instructions

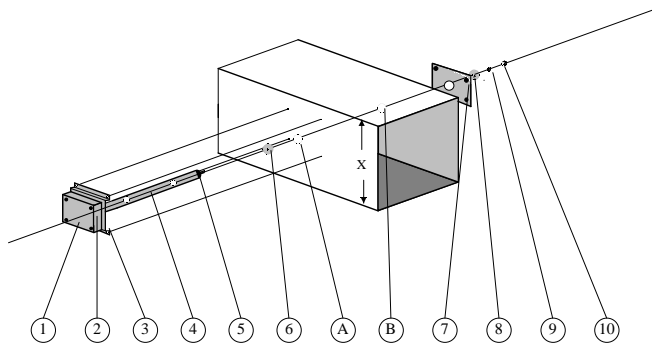

1. PHYSICAL INSTALLATION

1.1 ALL DUCTS

1.11 - Each package is labeled for serial number, duct size and location. Carefully open packages and inspect for damage.

1.12 - Locate the position on the duct indicated by the engineers plans where the air flow measuring station (AFMS) is to be located. Caution: Proper location of the flow station is critical for optimal sensor performance.

1.2 RECTANGULAR DUCTS

1.21 - Place a carpenters square along the edge of the duct which the probe will be inserted through. Mark a line perpendicular to the edge of the duct, perpendicular to flow, so that it traverses the distance "X" on in the figure above. This line will be used to locate the position of the hole which needs to be drilled for probe insertion.

1.22 - If the probe are greater than 18" they will have a terminal mounting bolt [5] protruding out of the side of the probe opposite the mounting bracket [3]. Repeat Step 1.21 directly across from where you marked the line for the probe to be inserted. If they do not have a terminal mounting bolt, ignore this step and any references to mounting hole B.

1.23 - Locate the mounting hole in the middle of the duct (0.5 X). Skip to step 1.4 - ALL DUCTS

1.3 ROUND DUCTS

1.31 - Locate a point on the duct where the probe will be inserted. If the duct is greater than 18" in diameter, mark both the insertion and terminal positions, otherwise, mark only the insertion side. The terminal position can be located by measuring across the circumference (outside) of the duct a distance 1.572X, where X is the duct outside diameter.

1.4 ALL DUCTS

1.41 - Using a 1 1/8 to 1 3/8 inch diameter drill, drill holes A and B where indicated.

1.42 - Place the probe assembly [4] though mounting hole A making sure that gasket [6] is firmly against mounting plate [3]. Fasten mounting plate [3] to duct with appropriate sheet metal screws making sure that the edge of the plate which mounts to the duct is as parallel as possible to the edge of the duct and is oriented properly for the direction of flow.

1.43 - If the probe assembly has a terminal mounting bolt [5]

then follow steps 1.44 through 1.46 ,otherwise skip to section 2. WIRING.

1.44 - Place terminal mounting bracket [7] onto terminal bolt [5] which should now be protruding out the opposite side of the duct. Fasten mounting plate [7] to duct with appropriate sheet metal screws.

1.45 - Place foam shock absorber/gasket over terminal mounting bolt [5] then place washer [9] against shock absorber.

1.46 - Tighten lock nut [10] onto terminal mounting bolt until snug. A tight fit is not required and will allow for duct movement during system operation.

2. FIELD WIRING

2.1 ALL SYSTEMS

2.11 - USE ONLY 24V AC POWER. EACH SYSTEM SHOULD HAVE A DEDICATED 10 VA CLASS 2 TRANSFORMER OR MUST OTHERWISE BE ISOLATED FROM OTHER DEVICES POWERED FROM THE SAME SOURCE. **USE THE 1:1 ISOLATION TRANSFORMER PROVIDED ON EACH PROBE TO ASSURE ISOLATION FROM OTHER DEVICES.**

2.12 - USE CAUTION AND MAKE SURE THAT POWER IS NOT APPLIED TO THE SIGNAL WIRING. DOING SO WILL DAMAGE THE ELECTRONICS AND VOID WARRANTY.

2.13 - ALL POWER CONNECTIONS MUST BE MADE IN PHASE BETWEEN EBTRON EQUIPMENT SHARING A SINGLE TRANSFORMER.

2.14 - GROUNDING POWER TO EARTH WILL RESULT IN DAMAGE TO THE PRINTED CIRCUIT BOARD, OTHER ELECTRONIC COMPONENTS OR THE HOST SYSTEM.

2.15 - Probe systems provide both airflow and temperature output as indicated on the identification tag on the electronics enclosure. The default output is 0-5 VDC. Optionally, the output can be ordered as 4-20 mA. Unless specified when ordered, probes with 4-20 mA airflow output signals will be supplied with the default 0-5 VDC temperature output. Check the identification tag on the electronics enclosure to determine the types of output signals and output scaling for each probe.

2.16 - Connect field wiring to the probe terminal blocks as indicated in figure 2.1.

Figure 2.1 - Probe Terminal Connections

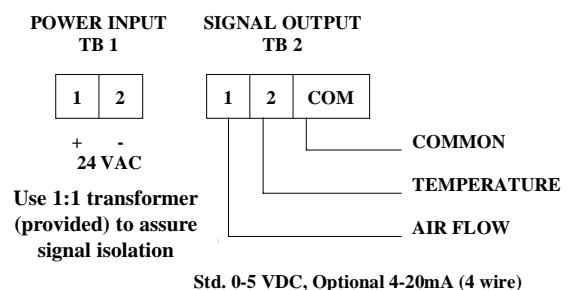

Std. 0-5 VDC, Optional 4-20mA (4 wire)