

Fan Inlet Sensor with Forward Mount

Installation Guide

-F Fan Inlet Sensors

with Forward Mount Brackets (Part number 700-50xx)
For use with Gold Series GF2 and
Hybrid Series HF1/SF1 Fan Inlet Sensors

Document Name: IG_F_FORWARD_R1A

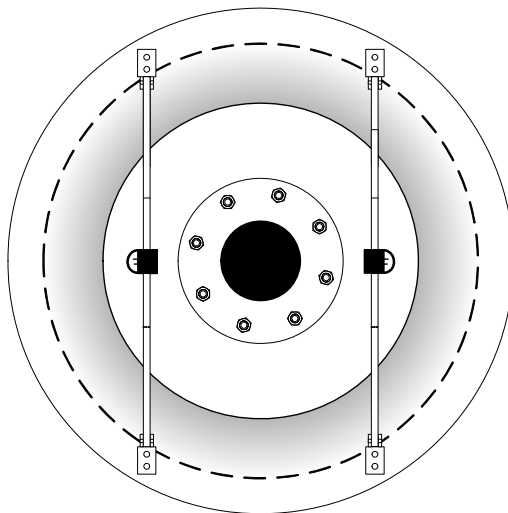

Fan Inlet Sensor Forward Mount

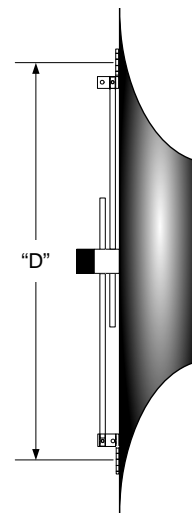

Part Number 930-0090_Forward

Table of Contents

1 OVERVIEW.....	3
2 PREPARATION FOR INSTALLATION.....	4
3 FAN INLET SENSOR WITH FORWARD MOUNT KIT INSTALLATION.....	5

List of Figures

Figure 1. Fan Inlet Sensor with Forward Mount Kit Components	3
Figure 2. Typical Application, Fan Inlet Sensor Forward Mount.....	4
Figure 3. Fan Inlet Forward Mount Installation Detail.....	5

List of Tables

Table 1. Forward Mount Standard Sizes.....	3
Table 2. Forward Mount Dimension 'X' Determination.....	6

1 OVERVIEW

This document provides the instructions necessary to install Fan Inlet Sensors supplied with Forward Mount Brackets (P.N. 700-50xx) as shown in Figures 1 and 2.

For DWDI (Dual Wheel Dual Inlet) and SWSI (Single Wheel Single Inlet) applications, sensors are always factory specified in pairs at the inlet opening. **Only on Fan Array applications may single sensors be specified by the factory for single left or single right installation.** Table 1 shows standard Forward Mount Sizes available. Forward mount mounting rods have straight rods and brackets for mounting on the face of sensitive plenum fans as shown in Figure 2.

Table 1. Forward Mount Standard Sizes

Standard Size Code	Inlet Face Diameter				Rod Pack Part Number (2 rods per pack)	Rod Pack Part Number (4 rods per pack)
	is greater than or equal to:		and is less than:			
	inches	mm	inches	mm		
1	7	177.80	13	330.20	700-5155	700-5055
2	10	254.00	18	457.20	700-5156	700-5056
3	14	355.60	25	635.00	700-5157	700-5057
4	19	482.60	35	889.00	700-5158	700-5058
5	27	685.80	50	1270.00	700-5159	700-5059
6	40	1016.00	64	1625.60	700-5160	700-5060

"D" Inlet Face Diameter - Measure Across Flat Face at Flare Edge

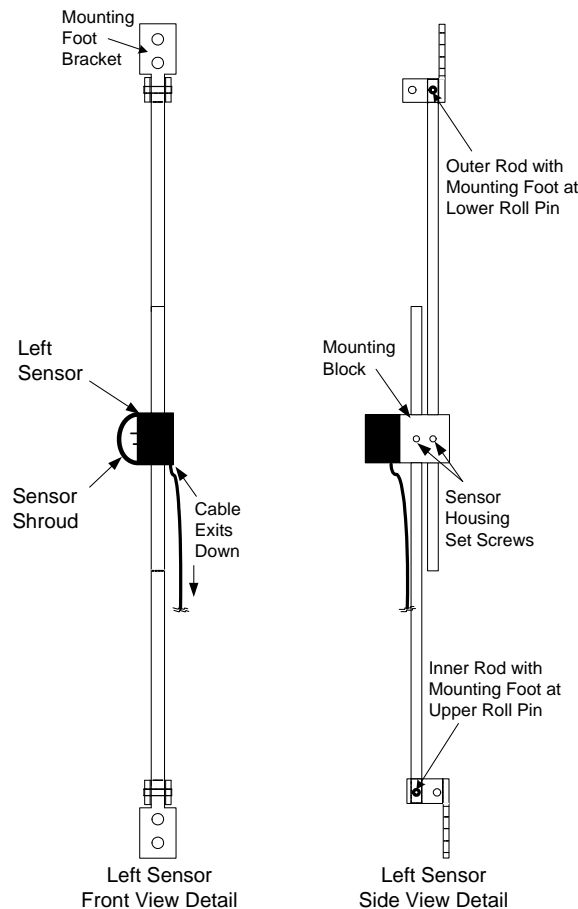

Figure 1. Fan Inlet Sensor with Forward Mount Kit Components

IG_F_FORWARD_R1A

2 PREPARATION FOR INSTALLATION

- a. Determine the specified location for the Fan Inlet Airflow Sensor as indicated on the engineer's plans. Ensure that the cable supplied with the sensor is of sufficient length to reach the planned transmitter installation site. It is recommended that the sensor be installed first to ensure that the included cable will reach the transmitter after routing and securing the cable.
- b. Carefully open the Fan Inlet Sensor and Forward Mount Installation Kit packages and inspect for damage. If damage is noted, immediately file a claim with carrier.
- c. Forward mount sensors are supplied with straight rods and brackets for mounting on the face of plenum fans as shown in Figure 2. Verify that the proper rods have been supplied for the intended application before proceeding with installation using Table 1.



CAUTIONS/WARNINGS

Select suitable hardware for the installation and ensure that the hardware will not interfere with the moving parts of the fan. Failure to properly secure the fan inlet sensor can result in personal injury and damage to sensors and fan.

Setting the specified rod length is essential for proper installation and sensor performance.

The cable ordered must be of sufficient length for the distance between the transmitter and the furthest sensor probe as well as any necessary cable routing at the site.

Improper or excessive lubrication of the fan bearings can result in lubricant carry over and build up of foreign material on the sensor.

Avoid placement in the absorption area of humidifiers which will adversely affect performance.

Failure to properly install, set up and/or secure the Fan Inlet sensor assembly can result in sensor and/or fan damage.

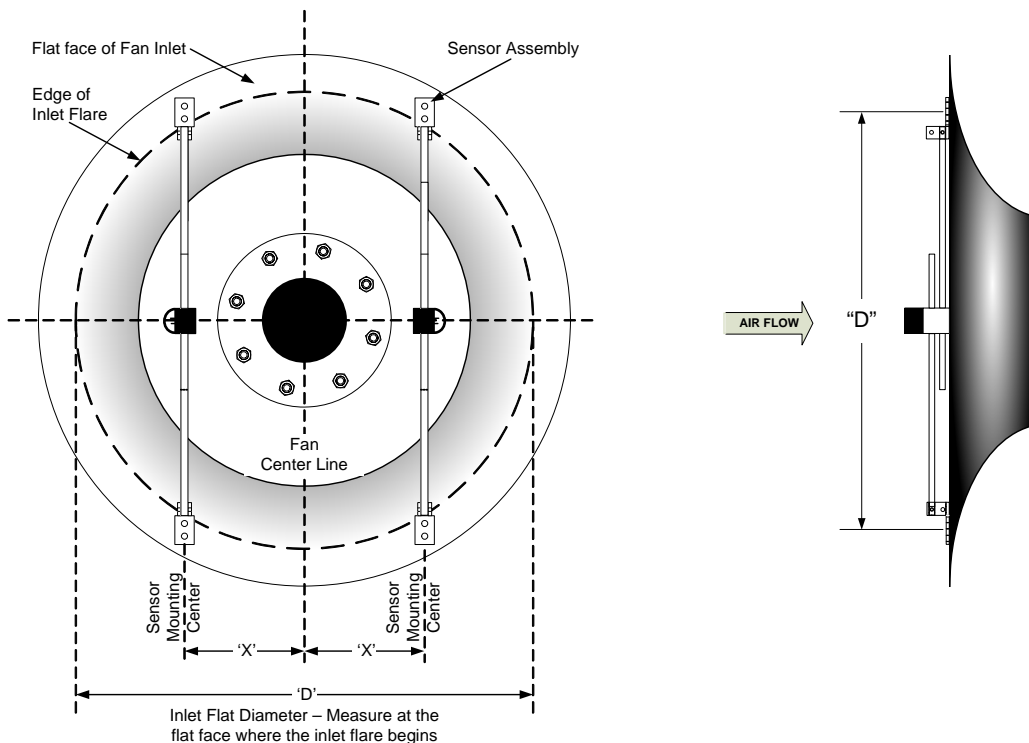
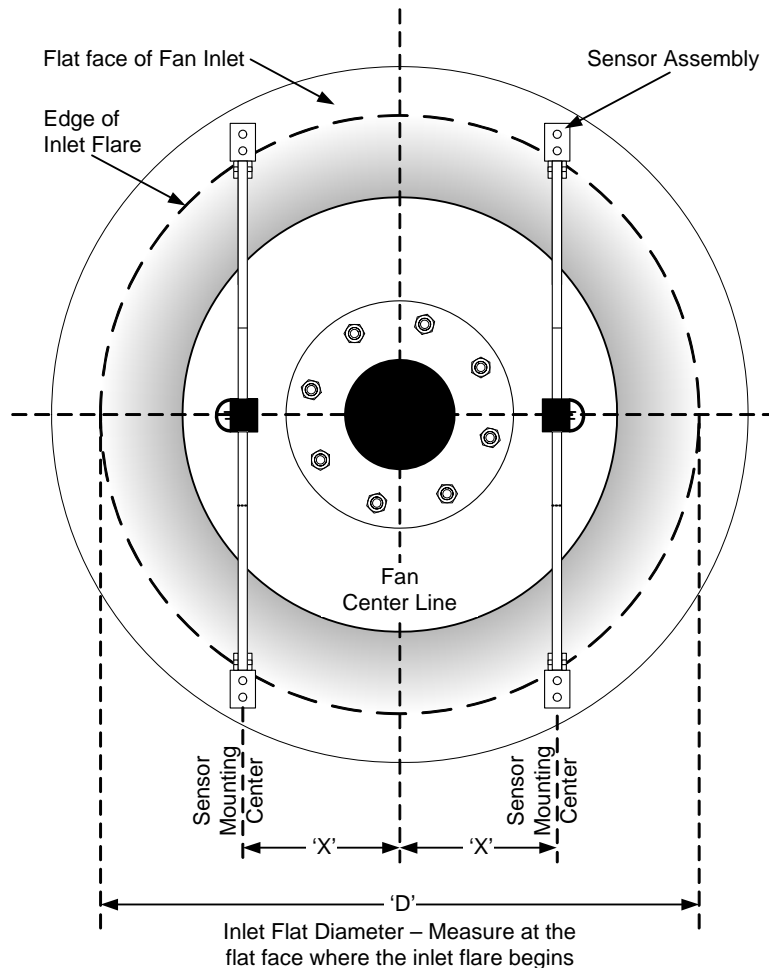

Figure 2. Typical Application, Fan Inlet Sensor Forward Mount

3 FAN INLET SENSOR WITH FORWARD MOUNT KIT INSTALLATION

For DWDI (Dual Wheel Dual Inlet) and SWSI (Single Wheel Single Inlet) applications, sensors are always factory specified in pairs at the inlet opening. **Only on Fan Array applications may single sensors be specified by the factory for single left or single right installation.** Sensors are marked for their intended location (INSIDE LEFT, INSIDE RIGHT) in the fan inlet, and all cables must exit downward. DWDI and SWSI inlet sensor pairs shall be parallel to one another. Check for obstructions at the fan inlet prior to installation. It may be necessary to rotate the orientation of the sensors to avoid any interfering obstructions in the fan inlet. Refer to Figures 1, 2 and 3 for installation detail. For specific installation questions, concerns or assistance, please contact EBTRON Applications Engineering Team at 800.2EBTRON (800.232-8766).

- a. Physically locate the fan where the air flow measuring station is to be installed on the engineer's plans.
- b. For sensors marked "INSIDE LEFT", insert an inner mounting rod (with mounting bracket attached at inner roll pin) into sensor mounting block inner rod hole with sensor oriented as in Figure 1.
- c. Insert outer mounting rod (with mounting bracket attached at outer roll pin) into sensor mounting block outer rod hole (Figure 1).
- d. For sensors marked "INSIDE RIGHT", repeat steps c and d with sensor shroud oriented to the right (opposite) as in Figure 1.
- e. Measure the diameter ('D') of the fan inlet FLAT FACE, measured at the flat portion of the flat face of the inlet at the point where the inlet flare just begins (Figure 3).



X = distance between fan center line and sensor center line

Figure 3. Fan Inlet Forward Mount Installation Detail

- f. Using Diameter 'D', locate DIMENSION 'X' in Table 2 to determine the fan inlet center line to sensor mounting center line for each sensor as shown in Figure 3.

Table 2. Forward Mount Dimension 'X' Determination

Inlet Face Diameter "D" (in.)	X (in.)	Inlet Face Diameter "D" (mm)	X (mm)	Inlet Face Diameter "D" (in.)	X (in.)	Inlet Face Diameter "D" (mm)	X (mm)	Inlet Face Diameter "D" (in.)	X (in.)	Inlet Face Diameter "D" (mm)	X (mm)
6	1 10/16	152.40	41.28	26	8 11/16	660.40	220.66	46	15 12/16	1168.40	400.05
7	2	177.80	50.80	27	9 1/16	685.80	230.19	47	16 2/16	1193.80	409.58
8	2 5/16	203.20	58.74	28	9 6/16	711.20	238.13	48	16 8/16	1219.20	419.10
9	2 11/16	228.60	68.26	29	9 12/16	736.60	247.65	49	16 13/16	1244.60	427.04
10	3 1/16	254.00	77.79	30	10 2/16	762.00	257.18	50	17 2/16	1270.00	434.98
11	3 6/16	279.40	85.73	31	10 8/16	787.40	266.70	51	17 8/16	1295.40	444.50
12	3 12/16	304.80	95.25	32	11	812.80	279.40	52	17 14/16	1320.80	454.03
13	4 2/16	330.20	104.78	33	11 3/16	838.20	284.16	53	18 4/16	1346.20	463.55
14	4 7/16	355.60	112.71	34	11 8/16	863.60	292.10	54	18 9/16	1371.60	471.49
15	4 12/16	381.00	120.65	35	11 14/16	889.00	301.63	55	18 15/16	1397.00	481.01
16	5 3/16	406.40	131.76	36	12 4/16	914.40	311.15	56	19 4/16	1422.40	488.95
17	5 8/16	431.80	139.70	37	12 10/16	939.80	320.68	57	19 10/16	1447.80	498.48
18	5 14/16	457.20	149.23	38	12 15/16	965.20	328.61	58	20	1473.20	508.00
19	6 3/16	482.60	157.16	39	13 8/16	990.60	342.90	59	20 6/16	1498.60	517.53
20	6 8/16	508.00	165.10	40	13 10/16	1016.00	346.08	60	20 11/16	1524.00	525.46
21	6 14/16	533.40	174.63	41	14	1041.40	355.60	61	21	1549.40	533.40
22	7 4/16	558.80	184.15	42	14 4/16	1066.80	361.95	62	21 7/16	1574.80	544.51
23	7 10/16	584.20	193.68	43	14 11/16	1092.20	373.06	63	21 12/16	1600.20	552.45
24	8	609.60	203.20	44	15 1/16	1117.60	382.59	64	22 2/16	1625.60	561.98
25	8 5/16	635.00	211.14	45	15 7/16	1143.00	392.11				

Refer to detail in Figure 3 for "D" Inlet Diameter and "X" distance between fan center line and sensor center line.

- g. Adjust the inner and outer rods of each sensor so that the distance between the left and right rod centers and the fan center line is equal to dimension 'X'. Now, adjust the mounting block so that the sensor body is located at the center of the rod. Tighten the set screws using the hex wrench provided.
- h. Install sensor assembly labeled "INSIDE LEFT" at the left side of the flat face of the fan inlet as in Figure 3. Use suitable hardware for installation that does not hinder rotation of the fan.
- i. Install sensor assembly labeled "INSIDE RIGHT" at the right side of the flat face of the fan inlet as in Figure 3. Use suitable hardware for installation that does not hinder rotation of the fan.
- j. Strap down sensor cables to mounting rods using the tie wraps provided (minimum of two tie wraps per sensor).
- k. Route sensor cables to transmitter and secure with appropriate hardware. Sensor installation is complete. Refer to separate technical manual TM_GTx116 for transmitter connection and set up.
- l. For dual fan inlet applications, repeat steps c through l to install sensors at the other fan inlet opening.

For any application specific installation questions, concerns or assistance, please contact the Ebtron Applications team at 800.2EBTRON (800. 232-8766).