

Gold Series Thermal Dispersion Airflow/Temperature Measurement Device (ATMD)



GTE116-F OVERVIEW

The GTE116-F is **EBTRON**'s top-of-the-line Gold Series thermal dispersion airflow and temperature measurement device (ATMD) designed for face or throat mounting in centrifugal, vane axial and plenum fan inlets. The GTE116-F is ideal for fan tracking applications where duct configurations preclude the use of duct and plenum probes and where repeatability and accuracy is paramount from 0-10,000 feet per minute. The ATMD includes the GTE116 industrial grade integrated transmitter and 10 BaseT Ethernet option for full duplex communication using BACnet[®] Ethernet, BACnet[®] IP, Modbus TCP or TCP/IP protocols and operation with virtually all modern building automation systems (BAS).

APPLICATIONS

- Volumetric airflow rate tracking for single and dual-inlet fan applications.
- Building pressurization control.
- Monitoring air changes.
- Temperature and humidity control.

SYSTEM FEATURES

- **EBTRON** Advanced Thermal Dispersion (TD) airflow measurement technology ensures accurate, repeatable measurement from zero flow (still air).
- Each sensor is factory calibrated at 16 points to **NIST-traceable standards**.
- Versatile design permit installation directly in the throat of centrifugal or vane axial fans, or on the face of more sensitive plenum fans.
- True average, multi-point, independent sensors.
- Highest quality, reliable and stable hermetically sealed "**bead-in-glass**" thermistors.
- Simple push-button user interface for field configuration and diagnostics.

GOLD SERIES
DATA SHEET

GTE116-F SPECIFICATIONS

System

Calibrated Range:0 to 10,000 fpm [50.8 m/s]
 Operating Temperature:Probe: -20 to 160 °F
 [-28.9 °C to 71.1 °C]
 Transmitter: -20 to 120 °F
 [-28.9 °C to 48.9 °C]
 Operating Humidity Range: .0 to 99% non-condensing;
 Transmitter must be protected from exposure to precipitation
 Power Requirements:24 VAC (22.8-26.4 VAC) at 12-13.1VA
 (based on sensor quantity)

Transmitter and Enclosure

Transmitter Construction: . .Heavy duty with industrial grade IC's and rugged aluminum chassis with sliding cover
 Transmitter Dimensions: . . .9.251 x 6.688 x 2.5 in (HxWxD)
 [234.98 x 169.87 x 63.5 mm]
 Transmitter Mounting:Four 0.188 in (4.76 mm) dia mounting holes located 0.75 in from top/bottom, and 0.375 from left/right edges on integral mounting plate

Sensor Probes

Sensor Construction:Two bead-in-glass thermistors in a GFP sensor housing sealed with waterproof marine grade epoxy.
 Mounting Brackets:Type 304 stainless steel
 Standard Size Ranges:From 11 to 64 in (27.9 to 162.56 cm) diameters using throat mount or face mount options for single or dual fan inlet applications.
 Maximum Probes/Sensors: Single Inlet: 2 probes/2 sensors
 Dual Inlet: 4 probes/2 sensors
 Factory Calibrated Sensor
 Accuracy:Airflow: ±2% of reading
 Temperature: ± 0.15 °F [± 0.08 °C]
 Probe/Transmitter Cable: . .10 ft. [3.05 m] plenum rated FEP cable, positive locking connector with gold plated pins (Optional length to 50 feet [15.24m])

Output Interface

10 Base-T Ethernet Output: Field selectable for BACnet[®] Ethernet, BACnet[®] IP, Modbus TCP or TCP/IP
 Repeatability:0.25% of reading
 Airflow Signal Adjustment: . .Field adjustable offset/gain (via pushbutton interface)
 Airflow Output Signal Filter: .0 to 99% (via pushbutton interface)
 Airflow Low Limit Cutoff: . . .Forces output to zero below a user-specified value

GOLD SERIES TECHNOLOGY OVERVIEW

The GTx116 transmitter can process up to 4 individual sensing nodes (two per inlet) for fan inlet applications and requires 24 VAC to provide airflow and temperature measurement outputs. Models are available with outputs for analog (GTA116), ethernet (GTE116), RS-485 (GTN116) and LonWorks (GTL116) BAS networks. The transmitter is independent of the sensor probes thus eliminating field matching. The transmitter includes a 16 character LCD display that indicates airflow, temperature and system status, and is also useful during configuration and diagnostic modes. Field configuration and diagnostics are accomplished through a simple push-button interface on the main circuit board for selection of units of measure, display units, output scaling, dampening filter, diagnostics and instrument status. Individual sensor airflow and temperature measurements can be displayed and are beneficial as an HVAC system diagnostic tool. The air-

flow output signal can be filtered and a process low limit can be set to force the transmitter output to zero when airflow falls below a user defined value. Both features are important for outside air intake applications that can be affected by transient wind gusts at low airflow rates. In addition, an airflow offset and a gain adjustment feature can be engaged for installations where field calibration or adjustment is necessary.

EBTRON's GF1 sensor probes are available for single or dual fan inlet designs in six standard sizes spanning inlet diameters from 11 to 64 in (27.9 to 162.56 cm). A Throat Mount installation option is available for conventional vane-axial type fans, while a Face Mount installation option permits installation on more sensitive plenum fan applications to minimize both noise and fan performance effects.

FAN INLET PROBE MOUNTING STYLES AND DIMENSIONS

THROAT MOUNT PROBE AND ADJUSTABLE MOUNTING BRACKET DETAIL

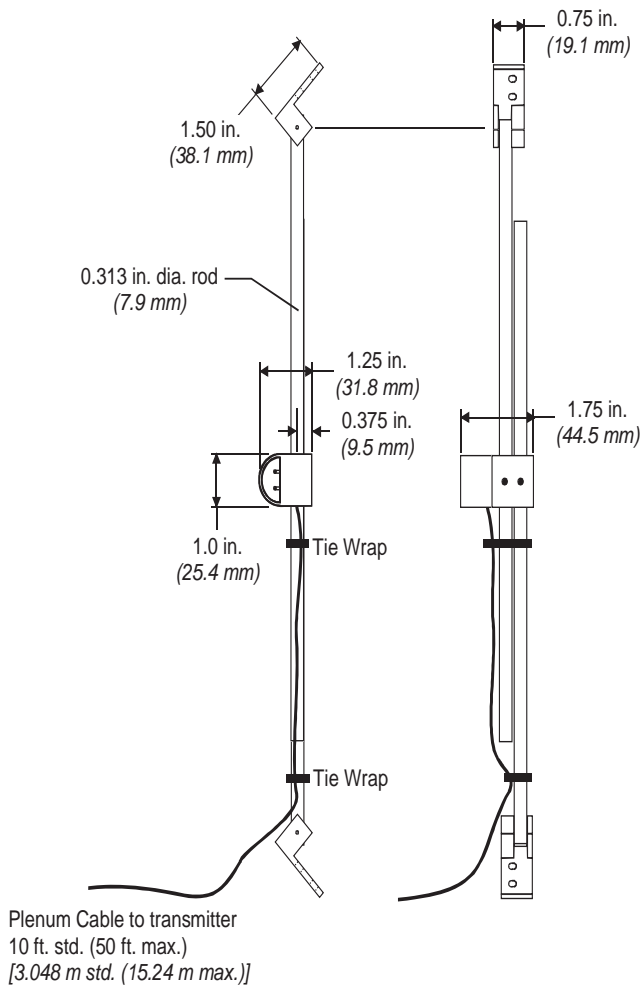

FACE MOUNT PROBE AND ADJUSTABLE MOUNTING BRACKET DETAIL

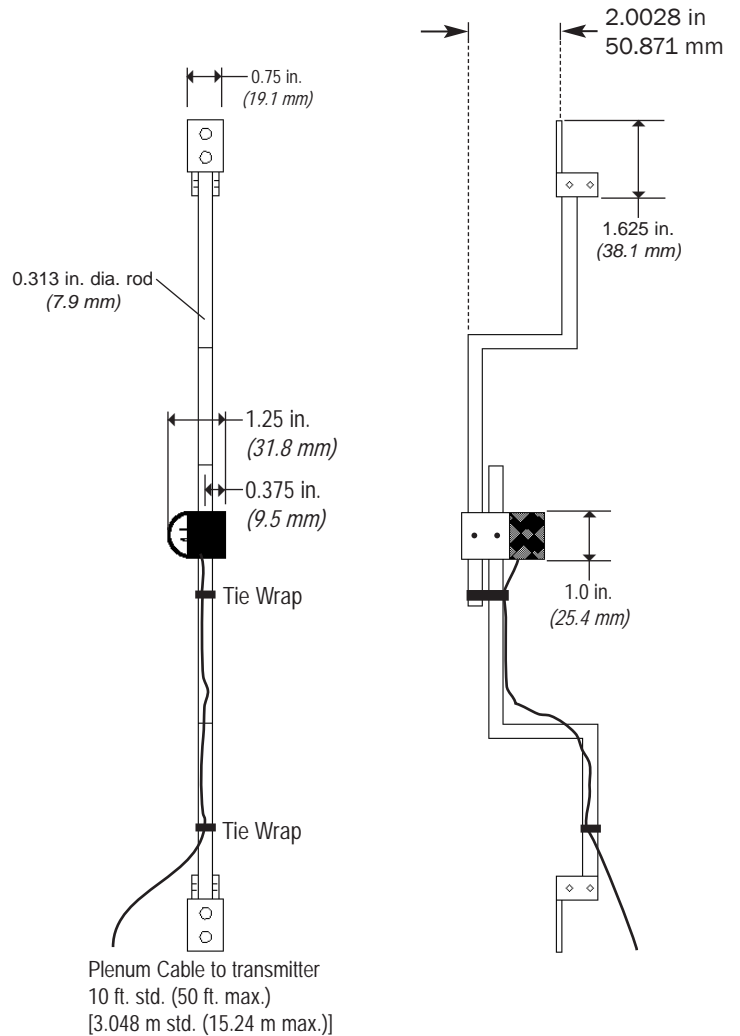

TS_GTE116F_R1A

FAN INLET PROBE PLACEMENT GUIDELINES

THROAT MOUNT PLACEMENT AND SIZING DETAIL

Throat Mount - Vane Axial Fan Application

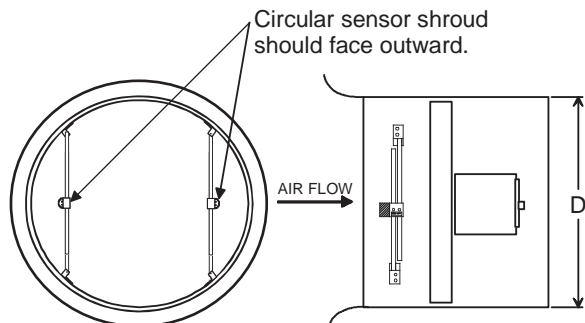

Throat Mount - Centrifugal Fan Application

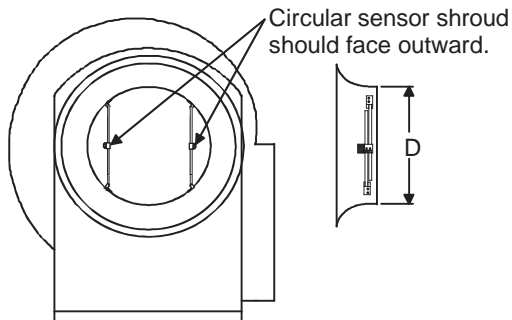

Throat Mount Standard Sizes

Standard Size Code	Inlet Throat Diameter				Rod 4 Pack Part Number
	is greater than or equal to		and is less than		
	inches	mm	inches	mm	
1	11	279.40	14	355.60	700-3055
2	14	355.60	17	431.80	700-3056
3	17	431.80	29	736.60	700-3057
4	29	736.60	43	1092.20	700-3058
5	43	1092.20	57	1447.80	700-3059
6	57	1447.80	64	1625.60	700-3060

"D" Inlet Throat Diameter is measured across the smaller inside diameter of the fan bell.

FACE MOUNT PLACEMENT AND SIZING DETAIL

Face Mount - Plenum Fan Application

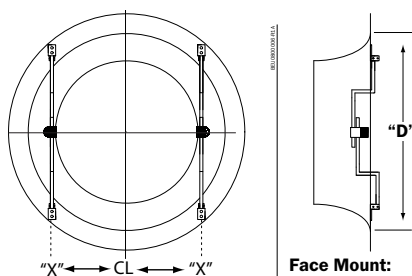

Face Mount:
"X" is the fan centerline to the sensor center dimension.

Face Mount:
"D" is the diameter of the face mount determined by the diameter of the flat portion of large inlet opening at the point where the flare begins.

Face Mount Standard Sizes

Standard Size Code	Inlet Face Diameter				Rod 4 Pack Part Number
	is greater than or equal to		and is less than		
	inches	mm	inches	mm	
1	11	279.40	13	330.20	700-4055
2	13	330.20	18	457.20	700-4056
3	18	457.20	23	584.20	700-4057
4	23	584.20	32	812.80	700-4058
5	32	812.80	46	1168.40	700-4059
6	46	1168.40	64	1625.60	700-4060

"D" Inlet Face Diameter is measured across the Flat Face at the Flare Edge at the diameter where the flare just begins.

TYPICAL WIRING DIAGRAM

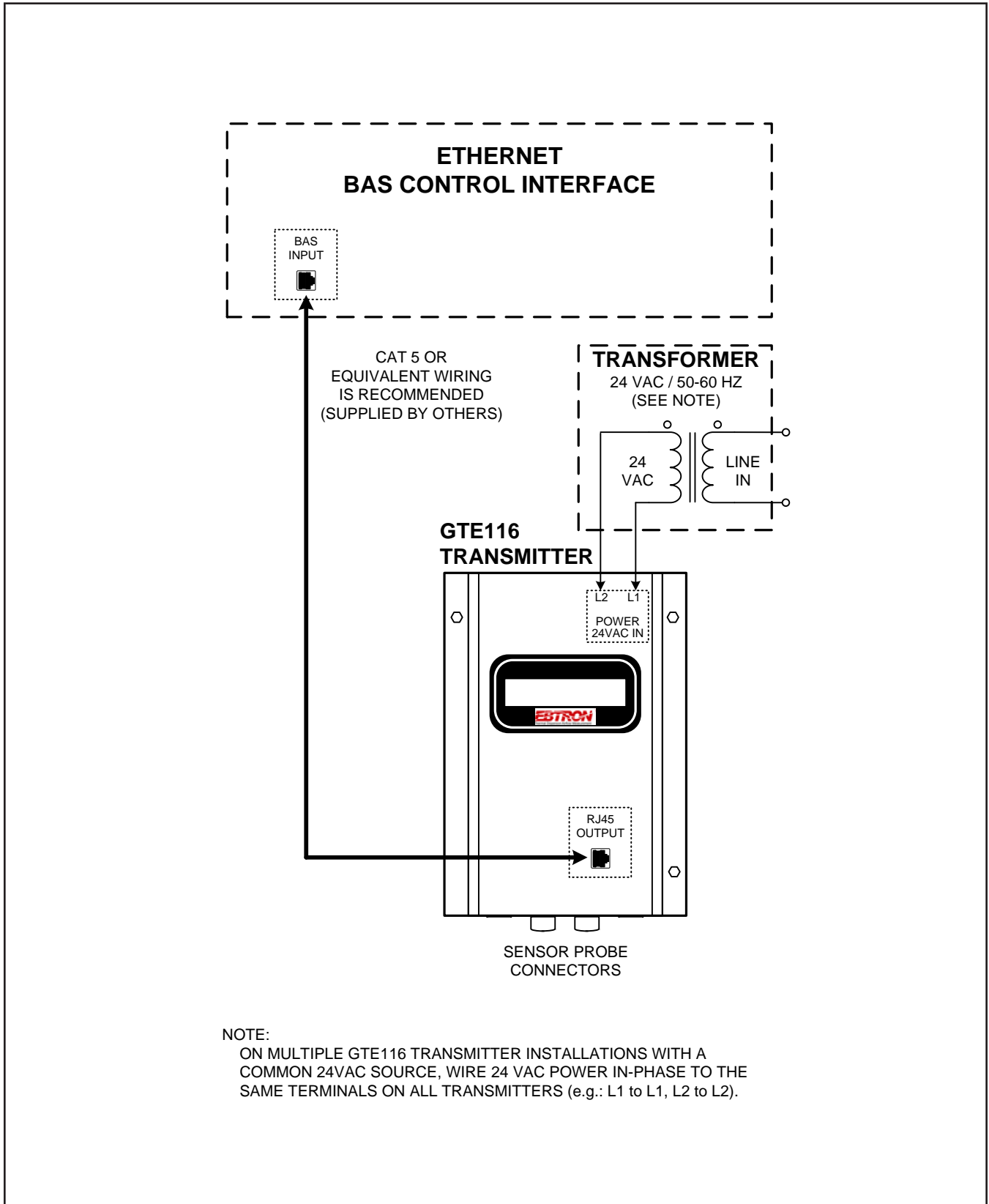

TS_GTE116F_R1A