

Advantage

Hybrid/Silver Series by Ebtron

Installation, Operation and Maintenance Technical Manual

HB1 / SB1

Bleed Airflow Sensors

For use with HTx104 and STx102 Transmitters

Includes Analog output models: HTA104-B and STA102-B
and RS-485 output model: HTN104-B

Document Name: *TM_HB1_SB1_R1D*

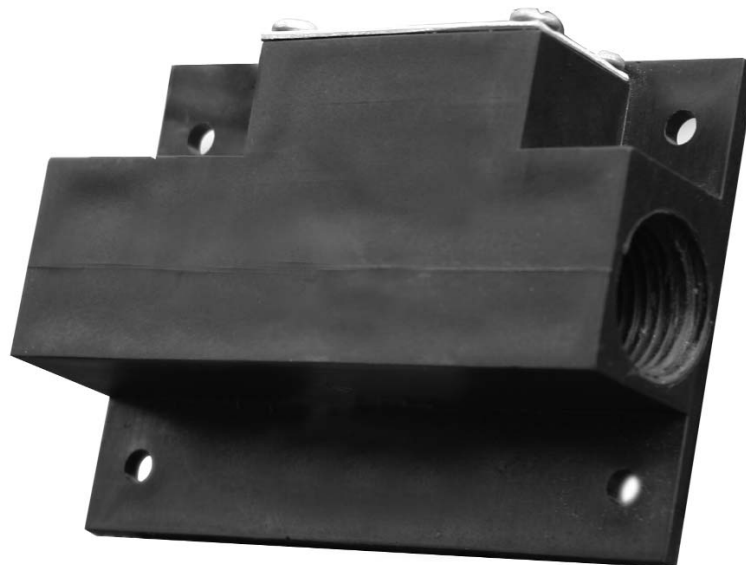

TM_HB1_SB1_R1D

HYBRID SERIES
TECHNICAL MANUAL

SILVER SERIES
TECHNICAL MANUAL

LIST OF EFFECTIVE AND CHANGED PAGES

Insert latest changed pages (in bold text); remove and dispose of superseded pages.
Total number of pages in this manual is **12**.

Page No	Revision *	Description of Change	Date
1	R1D	Remove STx104 references; Change revision to R1C	10/17/2011
2	R1D	Updated List of Effective pages	10/17/2011
4, 5	R1D	Removed all STx104 references	10/17/2011
11	R1D	Updated maintenance note regarding filtering	10/17/2011
1	R1C	Updated Title page revision to R1C	6/22/2009
2	R1C	Updated List of Effective pages	6/22/2009
12	R1C	Updated Fig 14 and 16 item 'D' from 0.75 in. NPT to 0.5 in NPT	6/22/2009
1, 2	R1B	Added part number; updated revision to R1B	03/19/2009
3 through 12	R1A	Initial document release	12/03/2008

* R1A indicates an original page without chang

Table of Contents

OVERVIEW 4

SPECIFICATIONS 4

ADVANCED TECHNOLOGY 4

APPLICATIONS 4

HB1 / SB1 MOUNTING OPTIONS 5

 Wall Mounting Kit 5

 Underfloor/Floor Mounting Kit 5

 Underfloor/Wall Mounting Kit 6

 Ducted Damper Mounting Kit 6

 Plenum Damper Mounting Kit 6

HB1/SB1 INSTALLATION 7

HB1/SB1 WALL MOUNT KIT INSTALLATION 7

 Converting to Actual Pressure 8

 Converting Velocity: Kv Factor Method 8

 Converting Uncorrected Pressure: Kp Factor Method 8

 Converting Airflow or Uncorrected Pressure to Actual Pressure Using the Polynomial Method 8

HB1/SB1 UNDERFLOOR/FLOOR MOUNTING KIT INSTALLATION 9

HB1/SB1 UNDERFLOOR/WALL MOUNTING KIT INSTALLATION 10

HB1/SB1 DUCTED DAMPER AND PLENUM DAMPER MOUNTING KITS 11

 Relief Damper Control (Relief Fan Systems) 11

 Return Damper Control (Relief Fan Systems) 11

MAINTENANCE 11

STANDARD LIMITED PARTS WARRANTY 11

List of Figures

Figure 1. EBTRON HB1/SB1 Bleed Sensor 4

Figure 2. HB1/SB1 Bleed Sensor 5

Figure 3. Wall Mounting Kit 5

Figure 4. Underfloor/Floor Mounting Kit 5

Figure 5. Underfloor/Wall Mounting Kit 6

Figure 6. Ducted Damper Mounting Kit 6

Figure 7. Plenum Damper Mounting Kit 6

Figure 8. HB1/SB1 Wall Mount Detail View 7

Figure 9. HB1/SB1 Wall Mount Installation Detail, Top View 7

Figure 10. HB1/SB1 Floor Mount Detail View 9

Figure 11. HB1/SB1 Floor Mount Installation Detail 9

Figure 12. HB1/SB1 Underfloor Wall Mount Detail View 10

Figure 13. HB1/SB1 Underfloor Wall Mount Installation Detail 10

Figure 14. HB1/SB1 Ducted Damper Mount Detail View 12

Figure 15. HB1/SB1 Ducted Damper Mount Installation Detail, Top View 12

Figure 16. HB1/SB1 Plenum Damper Mount Detail View 12

Figure 17. HB1/SB1 Plenum Damper Mount Installation Detail, Top View 12

List of Tables

Table 1. K Factors 8

Table 2. Polynomial Coefficients 8

Table 3. Underfloor Flush Mount Control Setpoint Determination 9

Table 4. Underfloor Wall Mount Control Setpoint Determination 10

TM_HB1_SB1_R1A

Copyright © 2008, EBTRON ®, Inc.
All brand names, trademarks and registered trademarks are the property of their respective owners. Information contained within this document is subject to change without notice. Visit EBTRON.com to view and/or download the most recent versions of this and other documents.
All rights reserved.

OVERVIEW

HB1/SB1 thermal dispersion bleed airflow sensors (Figure 1) accurately measure airflow and direction across defined pressure zones through a small opening (0.5 inch diameter x adjustable length). Extraordinary accuracy is ensured through individual sensor characterization over a range of -3,000 and +3,000 fpm (-15.2 and 15.2 m/s) in wind tunnels calibrated to NIST-traceable airflow standards. Measurement accuracy and repeatability of the airflow “bled” through the opening makes the HB1/SB1 ideal for control of supply airflow to underfloor systems. This application typically requires accurate pressure measurement of very low pressure differentials (near 0.05 in. WC - 12.45 Pa). Other applications include accurate monitoring and positive airflow control via relief and/or return air dampers, ensuring that they are only open when a specified amount of positive airflow is sensed by the instrument.

HB1/SB1 bleed airflow sensors use three “bead-in-glass” thermistors to determine the airflow rate, direction and temperature at each sensing location. Accuracy is percent of reading (not percent of full scale). Performance is ensured throughout the entire calibrated range. One bleed sensor can be connected to a single STx102 transmitter and up to two bleed sensors can be connected to an HTx104 transmitter for airflow or equivalent pressure output.. Airflow rate can easily be converted to equivalent pressure by simply applying an appropriate correction factor.

SPECIFICATIONS

Sensor Probe Configurations

- HTx104:
1 or 2 “Bleed” Sensors
- STx102: 1 “Bleed” Sensor

Sensor Accuracy

- Airflow: $\pm 2\%$ of reading, $\pm 0.25\%$ repeatability
- Temp: $\pm 0.15^\circ\text{F}$ ($\pm 0.08^\circ\text{C}$)

Sensor Ranges

- 0 to ± 0.5 in. WC
(0 to ± 125 Pa)
- 3,000 to +3,000 fpm
(-15.2 to +15.2 m/s)
- Temperature: -20°F to 160°F
(-28.9°C to 71.1°C)
- Humidity: 0 to 99% RH, non-condensing

Sensor Assembly (each sensing point)

- Heated element: Two bead-in-glass, hermetically sealed thermistors
- Temperature sensor: One bead-in-glass, hermetically sealed thermistor
- Sensor housing: Glass-filled polypropylene

- Sensor potting material: Marine grade, waterproof epoxy

Dimensions

- Length 3.75 in. (95.25 mm) x Height 1 in. (25.4 mm) x Width 2.625 in. (66.7 mm)
- Pipe and fitting connections: 0.5 in. (12.7mm) Female NPT 1 in. (279.4 mm) to 64 in. (1625.6 mm)

Cable Assembly

- Type: UL® Plenum Rated, PVC jacket
- Length: 10 ft std. (3.048 m), 50 ft (15.24 m) max.
- Termination: 0.625 in. circular DIN (15.875 mm) plug [transmitter end]

“Plug and Play” Sensor Probes

- Probes do not require matching to transmitter

Compatible Transmitters

- HTA104, HTN104, STA102

Warranty

- 36 months from shipment



Figure 1. EBTRON HB1/SB1 Bleed Sensor

ADVANCED TECHNOLOGY

- EBTRON Advanced Thermal Dispersion (TD) airflow measurement technology ensures accurate, repeatable measurement from zero flow (still air).
- Each sensor is factory calibrated to **NIST-traceable standards**.
- Highest quality, extremely stable hermetically sealed “bead-in-glass” thermistors.
- Exclusive “Plug and Play” SMART sensor design with provision for up to: 2 bleed sensors (HTx104-B) 1 bleed sensor (STA102-B).
- Versatile mounting options for placement in the most challenging field locations.

APPLICATIONS

- Bi-directional airflow and pressure measurement.
- Adjacent zone pressure monitoring.
- Pressure monitoring for cfm reset.
- Underfloor system supply airflow control (maintain low underfloor pressures).
- Independent, positive control of relief dampers.
- Indirect outside air measurement across fixed orifices.
- Monitor containment and isolation zones (LEED EQ applicable).

HB1 / SB1 MOUNTING OPTIONS

HB1/SB1 bleed sensor probes (Figure 2) are designed for use with HTx104 and STx102 transmitters. HB1/SB1 bleed sensor mounting kits are available in five styles for virtually any installation application.

- The wall mounting kit (Figure 3 - P.N. 800-1240) is designed for through-the-wall measurement between adjacent spaces (wall thickness 5 to 8 inches (127 to 203 mm)).
- The underfloor/floor mounting kit (Figure 4 - P.N. 800-1255) is ideal for floor panel installations above underfloor plenums.
- The underfloor/wall mounting kit (Figure 5 - P.N. 800-1260) is designed for wall mount applications located above an underfloor plenum.
- The ducted damper mounting kit (Figure 6 - P.N. 800-1245) is designed for duct mounted dampers that have access on both sides of the damper.
- The plenum damper mounting kit (Figure 7 - P.N. 800-1250) is designed for plenum mounted dampers or louvers.

NOTE:

The maximum length of bleed tubing supplied in the standard HB1/SB1 installation kit is 36 inches (914 mm).

Wall Mounting Kit

Wall mounting kit (Figure 3 - P.N. 800-1240) allows for mounting between pressure zones 5 to 8 inches wide (127 to 203.2 mm). For wider applications, contact **EBTRON**. Each kit contains two 304 stainless steel face plates with stainless steel screens, male NPT reducer and NPT male extension that can be trimmed to fit the desired wall thickness. The reducer and extension are made out of durable polyethylene.

Underfloor/Floor Mounting Kit

Underfloor mounting kit (Figure 4 - P.N. 800-1255) is designed for flush floor panel mounting in underfloor systems to ensure stable control of inherently low floor plenum pressure. Since most underfloor systems are maintained near 0.05 in. WC, a small change in pressure can result in a very large change in flow through the diffusers (a control fluctuation of ± 0.01 in. WC will result in approximately $\pm 10\%$ flow variation through the diffuser). Other commercially available HVAC pressure sensors are unstable at these low pressures. A protective screen protrudes approximately 1-3/8 inches above the floor surface, therefore, high traffic areas should be avoided. Each kit contains one 304 stainless steel face plate with stainless steel screen and a male NPT reducer.



Figure 2. HB1/SB1 Bleed Sensor



Figure 3. Wall Mounting Kit



Figure 4. Underfloor/Floor Mounting Kit

Underfloor/Wall Mounting Kit

Underfloor wall mounting kit (Figure 5 - P.N. 800-1260) is designed for wall mounting, above an underfloor air system, to ensure stable control of inherently low floor plenum pressure. Since most underfloor systems are maintained near 0.05 in. WC, a small change in pressure can result in a very large change in flow through the diffusers (a control fluctuation of ± 0.01 in. WC will result in approximately $\pm 10\%$ flow variation through the diffuser). Other commercially available HVAC pressure sensors are unstable at these low pressures. Each kit contains one 304 stainless steel face plate with stainless steel screen, a male NPT reducer, a right elbow and an NPT male pipe.



Figure 5. Underfloor/Wall Mounting Kit

Ducted Damper Mounting Kit

Ducted damper mounting kit (Figure 6 - P.N. 800-1245) is designed for duct mounted relief dampers (supply/return fan systems) or return dampers (supply/relief fan systems) with access on both sides of the damper, to ensure positive airflow control during periods of relief/exhaust at the air handling unit (AHU). It can also be used on systems where mixed air plenum pressure control is implemented to maintain minimum outside air intake flow rates. The kit is provided with flexible hose and fittings to simplify installation.

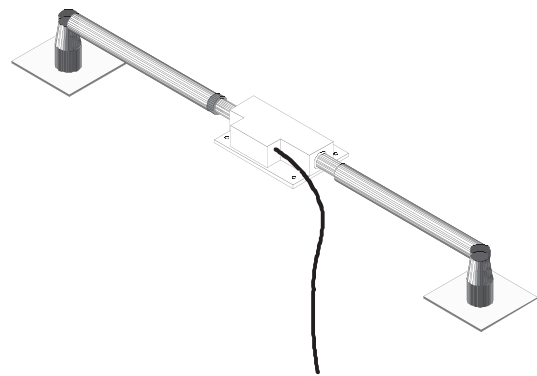

Figure 6. Ducted Damper Mounting Kit

Plenum Damper Mounting Kit

Plenum damper mounting kit (Figure 7 - P.N. 800-1250) is designed for plenum mounted dampers or louvers to ensure positive relief air damper control and prevent negative airflow through the relief flow circuit. This application also minimizes negative airflow during switch over from minimum outside air to economizer modes, especially on multi-story buildings where stack pressure can be problematic. The kit is provided with flexible hose and fittings to simplify installation.



Figure 7. Plenum Damper Mounting Kit

TML_HB1_SB1_R1A

HB1/SB1 INSTALLATION

The following paragraphs detail installation of the HB1/SB1 bleed airflow sensor with each of the five installation mounting kits.

For specific installation questions, concerns or assistance, please contact the **EBTRON** Applications Engineering Team at 1-800-2-EBTRON (1-800-232-8766).

HB1/SB1 WALL MOUNT KIT INSTALLATION

Figures 8 and 9 show installation details for the HB1/SB1 Wall Mounting kit between two adjacent spaces. Mount the bleed sensor so that the airflow directional arrow points from the high pressure side to the low pressure side of the installation.

The bleed sensor requires a 3 inch (76.2 mm) opening through the wall. Each opening is covered by the stainless steel face plates provided. The plates should be secured and sealed to the wall surface. If one pressure zone is exposed to rain or snow, a rain shield or louver (provided by others) must be used on the exterior wall surface to avoid water carry over into the sensor.

A standard 10 foot (3.048 m) plenum rated cable (up to 50 ft. [15.24 m] available) with terminal plug must be run to a remotely mounted transmitter (see appropriate transmitter manual based on model selected).

Transmitter factory default output is uncorrected for friction and entry losses of the bleed sensor and mounting assembly. A 'K' factor can be applied to the uncorrected pressure or airflow to compensate for such losses. Select the K factor from Table 1 for the nominal operating pressure. If you wish to display the corrected pressure on models with an LCD display, you must use the K_p factor method as outlined in the following paragraph.

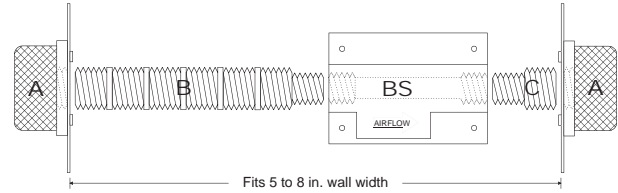

Label	Qty.	Description
A	2	4 in. x 4 in., 304 stainless steel face plate with protective mesh screen. Accepts 0.75 in. (19.05 mm) NPT male pipe or fitting.
B	1	0.75 in. (19.05 mm) NPT male x 0.5 in. (12.7 mm) NPT cut-off extension.
BS	1	Bleed sensor assembly.
C	1	0.75 in. (19.05 mm) NPT male x 0.5 in. (12.7 mm) NPT reducer fitting.

Figure 8. HB1/SB1 Wall Mount Detail View

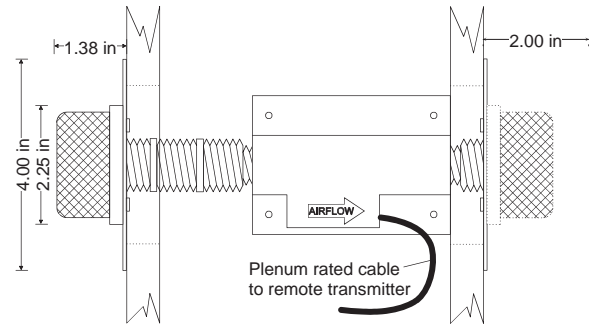

Figure 9. HB1/SB1 Wall Mount Installation Detail, Top View

Converting Velocity: Kv Factor Method

Controlling airflow, rather than pressure, is the most accurate method for the determination of differential pressure on analog input control and data logging devices since pressure is proportional to the square of the velocity. Setup the transmitter to output bidirectional airflow. To correct for the losses in the host control system, take the square of the velocity divided by the K_v factor from Table 1 (i.e. $\{\text{airflow measured by the host control system} / K_v\}^2$). To indicate corrected pressure on devices with an LCD display, set the LCD units of measure to in. WC (Pa for SI units) and enter K_p from Table 1. For transmitter configuration and setup details, refer to the associated transmitter Installation, Operation and Maintenance manual (under separate cover) for the model selected.

Converting Uncorrected Pressure: Kp Factor Method

Setup the transmitter to output bidirectional pressure. To correct for the losses in the host control system, scale the uncorrected pressure by the K_p factor from Table 1 (i.e. $K_p \times \text{uncorrected pressure measured by the host control system}$). To indicate corrected pressure on devices with an LCD display, set the LCD units of measure to in. WC (Pa for SI units) and enter K_p from Table 1. For transmitter configuration and setup details, refer to the associated transmitter Installation, Operation and Maintenance manual (under separate cover) for the model selected.

Converting Airflow or Uncorrected Pressure to Actual Pressure Using the Polynomial Method

The polynomial method is the most accurate method for converting to actual pressure when a wide range of pressure measurement is required. This method must be implemented in the host control system. Setup the transmitter to output bidirectional airflow and apply the polynomial values to the scaled output of the transmitter. To indicate the approximate corrected pressure on transmitters with an LCD display (HTx104), set the LCD units of measure to in. WC (Pa for SI units) and enter K_p for the nominal pressure from Table 1. For transmitter configuration and setup details, refer to the transmitter Installation, Operation and Maintenance manual (under separate cover) for the model selected.

Table 1. K Factors

Nominal Pressure (inWg)	K_v	K_p	Nominal Pressure (Pa)	K_v	K_p
0.0100	2241	3.192	2.4882	0.7217	3.192
0.0200	2460	2.651	4.9764	0.7920	2.651
0.0300	2523	2.521	7.4646	0.8122	2.521
0.0400	2583	2.405	9.9528	0.8316	2.405
0.0500	2661	2.265	12.4410	0.8569	2.265
0.1000	2854	1.969	24.8820	0.9190	1.969
0.2500	2977	1.810	62.2050	0.9585	1.810
0.5000	2992	1.792	124.4100	0.9633	1.792
0.7500	2962	1.828	186.6150	0.9538	1.828
1.0000	2963	1.828	248.8200	0.9539	1.828

Table 2. Polynomial Coefficients

Absolute Pressure Range		Corrected Pressure = $av^4 + bv^3 + cv^2 + dv + e$, where $v = \text{abs}\{\text{velocity}\}$				
		a	b	c	d	e
inWg	0 to 0.04		-5.4994E-11	1.5905E-07	9.4889E-06	0.0000E+00
	0.04 to 0.125	-4.5700E-13	1.4573E-09	-1.6064E-06	8.8239E-04	-1.5593E-01
	0.125 to 1.0	-2.6702E-15	2.1312E-11	6.7606E-08	1.4775E-05	1.9472E-02
Pa	0 to 10		-1.0444E-01	1.5341E+00	4.6486E-01	0.0000E+00
	10 to 30	-1.7088E-01	2.7676E+00	-1.5495E+01	4.3228E+01	-3.8800E+01
	30 to 300	-9.9843E-04	4.0473E-02	6.5210E-01	7.2384E-01	4.8450E+00

Note: Calculate polynomial coefficients using the absolute value of the velocity (i.e. unsigned) then apply the sign, positive or negative to the result.

HB1/SB1 UNDERFLOOR/FLOOR MOUNTING KIT INSTALLATION

Figures 10 and 11 show installation details for the HB1/SB1 underfloor floor mounting kit for underfloor systems.

As shown in Figure 11, mount the bleed sensor so that the airflow directional arrow points towards the floor (up). The bleed sensor requires a 3 inch (76.2 mm) opening through the floor. The opening is covered by the stainless steel face plate and protective screen provided. The plate should be secured and sealed to the floor. Do not place in expected high traffic areas since the protective screen protrudes approximately 1-3/8 inches above the floor surface. A standard 10 foot (3.048 m) plenum rated cable (up to 50 ft (15.24 m) available) with terminal plug must be routed to the remotely mounted transmitter.

Set up the transmitter to indicate unidirectional airflow. Determine the airflow rate that corresponds to the desired actual pressure required for proper operation of the underfloor diffusers (consult diffuser manufacturer for recommended pressure ranges). Controlling the airflow directly, rather than the pressure, will result in more stable pressure control.

If desired, the transmitter can be set up to indicate pressure on the LCD display. First, maintain the uncorrected pressure that corresponds to the actual pressure desired. Then, set K_p (in the transmitter setup) to display the corrected pressure on the LCD display. Refer to Table 3 for corrected setpoints. For transmitter configuration and setup details, refer to the associated transmitter Installation, Operation and Maintenance manual (under separate cover) for the model selected.

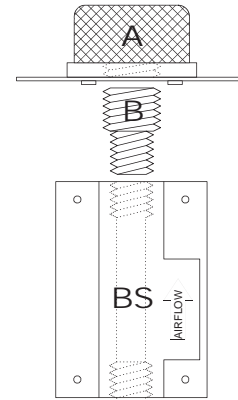

Label	Qty.	Description
A	1	4 in. x 4 in., 304 stainless steel face plate with protective mesh screen. Accepts 0.75 in. (19.05 mm) NPT male pipe or fitting.
B	1	0.75 in. (19.05 mm) NPT male x 0.5 in. (12.7 mm) NPT reducer fitting.
BS	1	Bleed sensor assembly.

Figure 10. HB1/SB1 Floor Mount Detail View

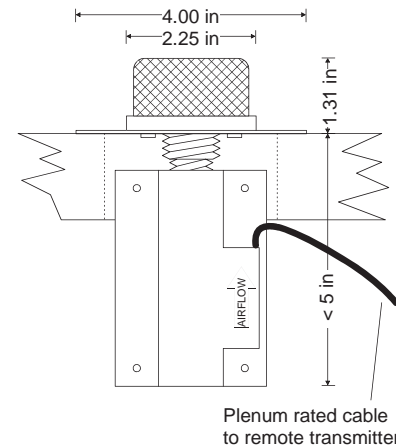

Figure 11. HB1/SB1 Floor Mount Installation Detail

Table 3. Underfloor Flush Mount Control Setpoint Determination

Desired Floor Pressure (inWg)	Control Setpoint (transmitter output)		K_p	Desired Floor Pressure (Pa)	Control Setpoint (transmitter output)		K_p
	Airflow	Pressure			Airflow	Pressure	
	(FPM)	(inWg)			(m/s)	(Pa)	
0.0200	346.1	0.0075	2.678	4.98	1.76	1.86	2.678
0.0300	442.9	0.0122	2.453	7.46	2.25	3.04	2.453
0.0400	529.1	0.0175	2.291	9.95	2.69	4.34	2.291
0.0500	606.3	0.0229	2.181	12.44	3.08	5.70	2.181
0.0600	675.8	0.0285	2.108	14.93	3.43	7.08	2.108
0.0700	738.4	0.0340	2.059	17.42	3.75	8.46	2.059
0.0800	795.1	0.0394	2.030	19.91	4.04	9.81	2.030
0.0900	846.5	0.0447	2.014	22.39	4.30	11.12	2.014
0.1000	893.1	0.0497	2.011	24.88	4.54	12.37	2.011

HB1/SB1 UNDERFLOOR/WALL MOUNTING KIT INSTALLATION

Figures 12 and 13 show installation details for the HB1/SB1 underfloor wall mounting kit for underfloor systems. Figure 13 shows proper mounting of a bleed sensor using the floor mounting kit through a floor plate.

As shown in Figure 13, mount the bleed sensor so that the airflow directional arrow points away from the floor (up). Drill a 1.0 inch (25.4 mm) hole through the base wall beam and floor where the bleed sensor will be mounted. The end of the tube should protrude slightly into the floor plenum. Secure the bleed sensor housing (BS in Figure 12) to a support beam or other suitable bracket so that the base of the sensor is approximately 2.25 inches (57.2 mm) from the interior wall surface (room side). The bleed sensor requires a 3 inch (76.2 mm) opening through the wall surface. The opening is covered by the stainless steel face plate (A, Figure 12) after the wall surface is installed. A standard 10 foot (3.048 m) plenum rated cable (up to 50 ft (15.24 m) available) with terminal plug must be run to the remotely mounted transmitter.

The transmitter can be set up to indicate unidirectional airflow. Maintain the airflow rate that corresponds to the desired actual pressure for proper operation of the underfloor diffusers (consult diffuser manufacturer for recommended pressure ranges). Controlling the airflow directly, rather than the pressure, will result in more stable control.

If desired, the transmitter can be set up to indicate pressure on the LCD display. First, maintain the uncorrected pressure that corresponds to the actual pressure desired. Then, set Kp (in the transmitter setup) to display the corrected pressure on the LCD display. Refer to Table 3 for corrected setpoints. For transmitter configuration and setup details, refer to the associated transmitter Installation, Operation and Maintenance manual (under separate cover) for the model selected.

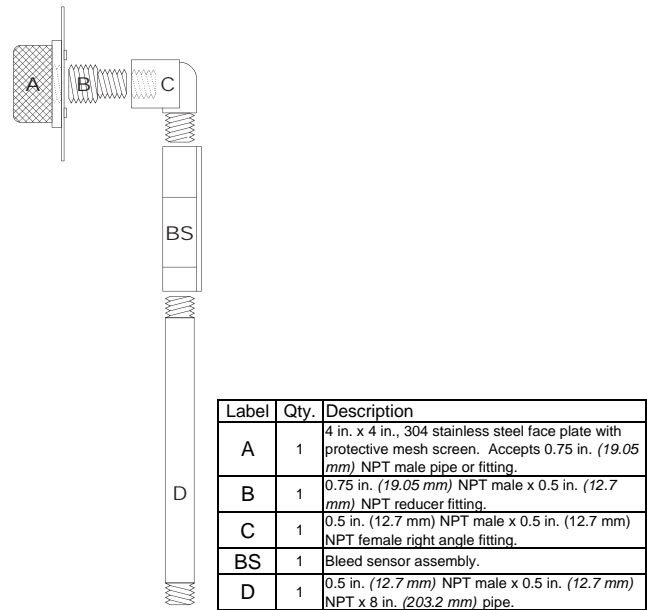

Figure 12. HB1/SB1 Underfloor Wall Mount Detail View

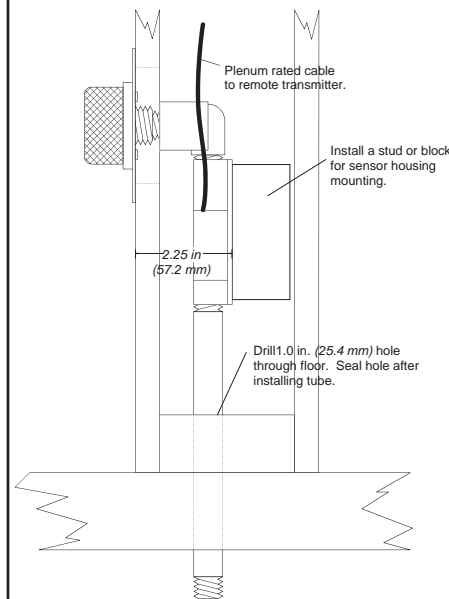

Figure 13. HB1/SB1 Underfloor Wall Mount Installation Detail

Table 4. Underfloor Wall Mount Control Setpoint Determination

Desired Floor Pressure (inWg)	Control Setpoint (transmitter output)		K _p	Desired Floor Pressure (Pa)	Control Setpoint (transmitter output)		K _p
	Airflow (FPM)	Pressure (inWg)			Airflow (m/s)	Pressure (Pa)	
0.0200	221.2	0.00305	6.556	4.98	1.12	0.76	6.556
0.0300	333.7	0.00694	4.321	7.46	1.69	1.73	4.321
0.0400	393.1	0.00964	4.151	9.95	2.00	2.40	4.151
0.0500	429.6	0.01150	4.346	12.44	2.18	2.86	4.346
0.0600	467.1	0.01360	4.410	14.93	2.37	3.39	4.410
0.0700	502.8	0.01576	4.442	17.42	2.55	3.92	4.442
0.0800	538.4	0.01807	4.427	19.91	2.73	4.50	4.427
0.0900	574.0	0.02054	4.381	22.39	2.92	5.11	4.381
0.1000	609.7	0.02317	4.315	24.88	3.10	5.77	4.315

TM_HB1_SB1_R1A

HB1/SB1 DUCTED DAMPER AND PLENUM DAMPER MOUNTING KITS

The following paragraphs detail installation of HB1 / SB1 sensors for relief and return damper control applications:

- Figures 14 and 15 show installation details for the HB1 / SB1 Ducted Damper Mounting kit. Figures 16 and 17 show installation details for the HB1 / SB1 Plenum Damper Mounting kit.
- For Ducted Damper kits, installation consists of drilling a 2 inch hole in both sides of the duct, leaving enough space to mount the 4 inch stainless steel plate.
- Similarly, for Plenum Damper Mounting kits, installation consists of drilling a 2 inch hole in the duct and plenum.
- Cut tubing to length and secure with the pipe clamps provided. Keep tubing straight to avoid kinks.
- Setup the transmitter to output unidirectional airflow (refer to the associated transmitter Installation, Operation and Maintenance manual under separate cover for the model selected).

Relief Damper Control (Relief Fan Systems)

Install the bleed sensor across the relief damper and open the damper to maintain an arbitrary positive flow or bleed pressure when relief is required at the AHU. Uncoupling the relief air damper from the outside air and recirculation dampers is an excellent way to get positive control of the relief air damper and avoid negative airflow through the relief flow circuit. Several of **EBTRON**'s control strategies recommend the use of a bleed sensor to avoid negative airflow during switch over from minimum outside air to economizer modes, especially on multi-story buildings where stack pressure can be problematic.

Return Damper Control (Relief Fan Systems)

Install the bleed sensor across the return damper and reset the maximum open position of the return damper to maintain a positive flow or bleed pressure when there is relief at the AHU. This method can avoid the short-circuit path between the outside air intake and relief fan that can occur when the return air damper is oversized.

MAINTENANCE

In most HVAC environments, periodic maintenance and calibration is neither required or recommended¹.

¹ In certain applications where a large amount of airborne particulate is present, especially fibrous material such as lint, pre-filtering of the return air may be required to ensure optimum instrument performance. If no pre-filtering is provided, it may be necessary to periodically inspect and clean sensors using compressed air or a small brush. Factory performance returns immediately after cleaning. Recalibration is NOT required. Periodic inspection of the sensors is always advised, and accessibility must be considered in these applications.

STANDARD LIMITED PARTS WARRANTY

If any **EBTRON** product fails within 36 months from shipment, **EBTRON** will repair/replace the device free of charge as described in the company's warranty contained in **EBTRON**'s *TERMS AND CONDITIONS OF SALE*. Defective equipment shall be shipped back to **EBTRON**, freight pre-paid, for analysis.

Label	Qty.	Description
A	2	4 in. x 4 in., 304 stainless steel plate with right angle 0.75 in. (19.05 mm) dia. hose barb.
B	4	Stainless steel hose clamps.
C	3 ft.	0.75 in. (19.05 mm) dia. nylon reinforced tubing.
D	2	0.5 in. (12.7 mm) NPT male x 0.75 in. (19.05 mm) dia. hose barb fitting.
BS	1	Bleed sensor assembly.

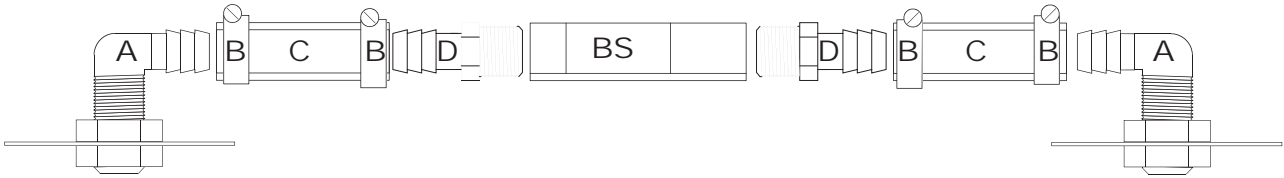

Figure 14. HB1/SB1 Ducted Damper Mount Detail View

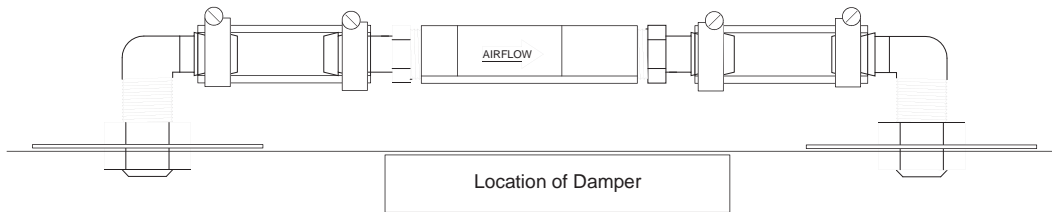

Figure 15. HB1/SB1 Ducted Damper Mount Installation Detail, Top View

Label	Qty.	Description
A	1	4 in. x 4 in., 304 stainless steel plate with right angle 0.75 in. (19.05 mm) dia. hose barb.
B	4	Stainless steel hose clamps.
C	3 ft.	0.75 in. (19.05 mm) dia. nylon reinforced tubing.
D	2	0.5 in. (12.7 mm) NPT male x 0.75 in. (19.05 mm) dia. hose barb fitting.
BS	1	Bleed sensor assembly.
E	1	4 in. x 4 in., 304 stainless steel plate straight 0.75 in. (19.05 mm) dia. hose barb.

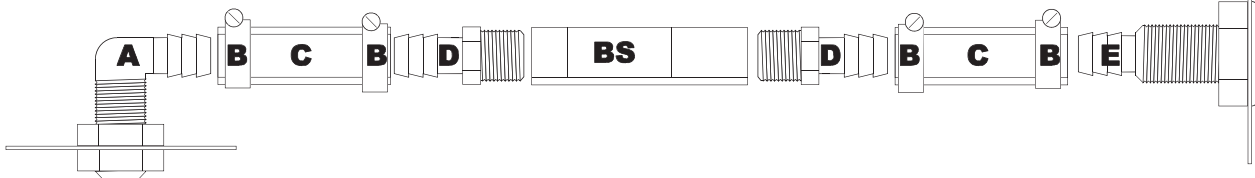

Figure 16. HB1/SB1 Plenum Damper Mount Detail View

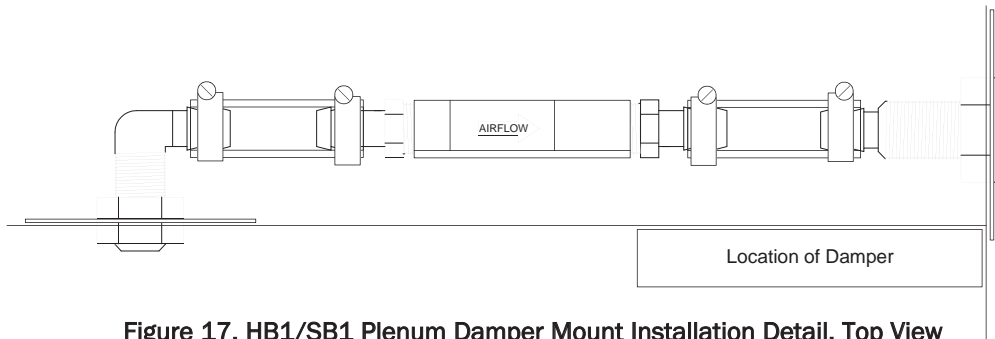

Figure 17. HB1/SB1 Plenum Damper Mount Installation Detail, Top View

TM_HB1_SB1_R1C