

GP1, HP1 AND SP1 DUCT AND PLENUM PROBE STANDOFF MOUNT INSTALLATION

OVERVIEW

This document provides the instructions necessary to install the probes using the Standoff Mount option as shown in Figure 1. The standoff mounting option is designed for outside air intake damper applications where duct extension sleeves cannot be added before them. Unducted standoff mounting can add additional uncertainty to system installed accuracy, which decreases as the damper size increases. Install directly in an outside air intake plenum or on an intake damper frame. The sensor probe is mounted 2 in (50.8 mm) from the full open damper blade position. Figure 2 shows a typical outside air intake damper frame installation using the standoff mount option. Figure 3 shows installation dimensions for the standoff mount probe. Standoff mounted probes are installed directly on an outside air plenum or on the damper frame.



Figure 1. Standoff Mount Probe Style

Installation consists of marking and preparing the mounting bracket hole locations and then installing and securing them. For detailed probe information, refer to the Duct/Plenum Probe technical manual under separate cover. For detailed information on transmitter set up and operation of the complete airflow measurement station, refer to the associated transmitter technical manual (under separate cover). Observe the following precautions during installation:

CAUTIONS/WARNINGS



Location of the probe(s) is critical for proper performance of the airflow station. Probes must be installed in accordance with the engineer's plans and **EBTRON** Minimum Placement Guidelines (Figures 5 and 6) for the specified location. For additional probe placement detail, refer to the probe technical manual under separate cover.



Standoff mounting may yield additional measurement uncertainty compared to duct mounted configurations and should only be used when additional duct sleeves cannot be added to the intake damper.



Ensure that adequate installation/service clearance exists at the installation site to permit installation of the probes and to prevent damper blade/linkage interference. Ensure that the cable length for the probes is sufficient to reach the planned transmitter installation.. Refer to the mechanical details of Figure 3.

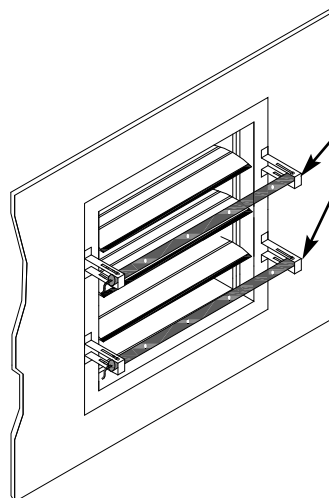

Probes supplied are 2 in. [50.8 mm] longer than the specified opening size to allow for bracket installation and damper blade clearance.

Install probes upstream of the outside air intake damper when extension sleeves cannot be added.

Figure 2. Standoff Mount Upstream Air Intake Damper Detail

NOTES

1. On applications where multiple probes are to be installed at a single measurement location, install probes in accordance with Figure 4. In addition, when traverse data is desired (on Gold Series GP1 probes only), place the lowest numbered probe at the top of the duct for horizontal mounting. For vertical mounting, place the lowest numbered probe on the left side of duct when viewed from the upstream side of the mounting location.
2. Insulation that interferes with mounting should be temporarily removed prior to installation and replaced afterwards.

STANDOFF MOUNT HOLE PREPARATION

Figure 3 details the Standoff Mount probe installation dimensions. Standoff mounting requires mounting the two end brackets, and then installing the probe onto the brackets. Install each probe as follows. Convenient check boxes are included to ensure that each step is completed.

1. Each probe package is factory labeled for the specific location and duct size for which it is designed. Orders for locations requiring multiple probes at a specific location are typically banded and packaged together.
The first dimension of the probe size indicates the length of the probe. The probes supplied are 2" longer than the opening to permit installation of the standoff mounting brackets, and to provide for damper blade clearance as shown in Figures 2 and 3. The second dimension indicates the mounting bracket side dimension 'X' as shown in Figure 4. Refer to Figure 3 and verify that the probe supplied is the correct size for the application.
Determine the specific duct/damper location for the probe(s) as indicated on the engineer's plans showing where the airflow measuring station is to be located. Refer to Figure 4 for probe spacing and orientation.
2. Carefully open the package and inspect for damage. Probe(s) will be installed in the outside air intake plenum or directly on the upstream side of an unducted intake damper as shown in Figure 2.
3. Using the Probe Spacing detail of Figure 4, locate and mark the location(s) where each of the probe brackets will be installed.
4. Refer to Figure 3 to determine the location of the mounting brackets for each probe from the edge of the plenum or damper opening. On damper applications, ensure that adequate mounting surface exists for the brackets on the damper frame. The brackets are 0.875 in (22.23 mm) wide, and an additional clearance of 0.125 in (3.175 mm) is provided between the inside edge of each bracket and the inside edge of the frame opening for mechanical clearance of damper blades/linkages, etc.
5. Fasten the mounting brackets to the opening with appropriate sheet metal screws making sure that the edge of the bracket is parallel to the edge of the opening.
6. Using the bracket hardware included, install probes so that the sensor probe is 2 in (50.8 mm) from the edge plane of the full open blades, and ensure that the printed arrows on the probe are oriented in the same direction as the airflow. Check mechanical damper operation and make any adjustments to the brackets necessary to prevent interference with the damper blades and linkage. Tighten all hardware securely.
7. Connect all sensor probes to the transmitter supplied for the specific location. This completes probe installation. Complete the installation, wiring and set up of the associated transmitter as detailed in the separate Transmitter Installation Guide and Installation, Operation and Maintenance Technical Manual (each provided under separate cover).

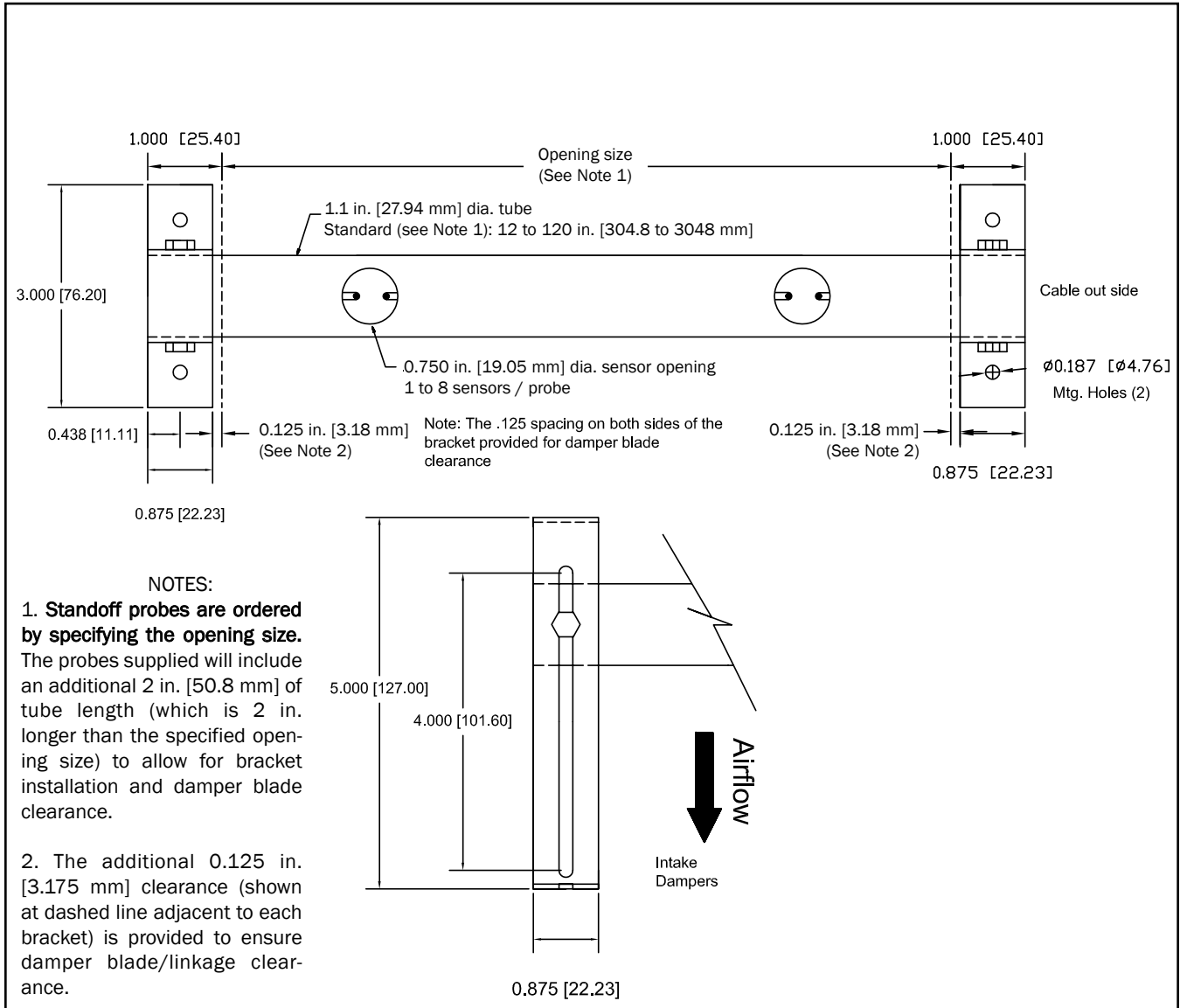

Figure 3. Standoff Mount Probe Mechanical Dimensions

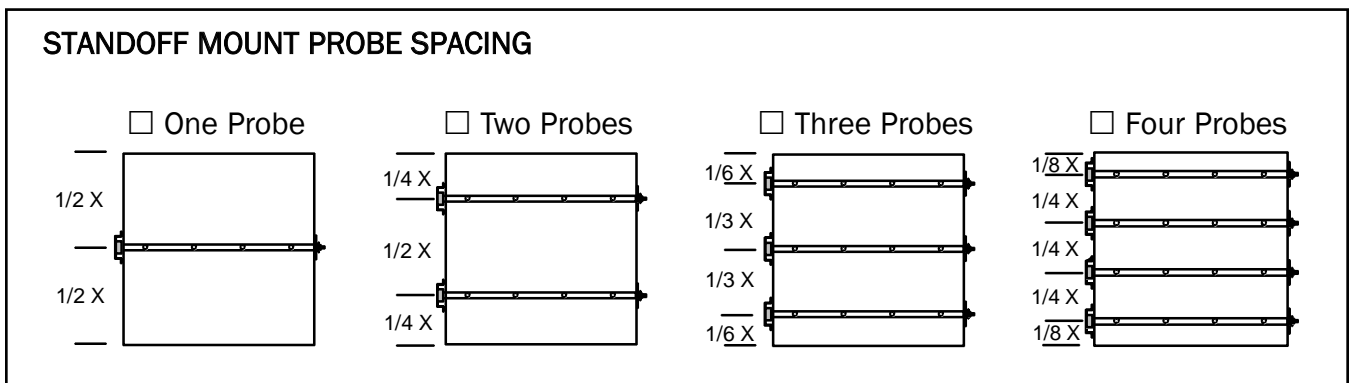
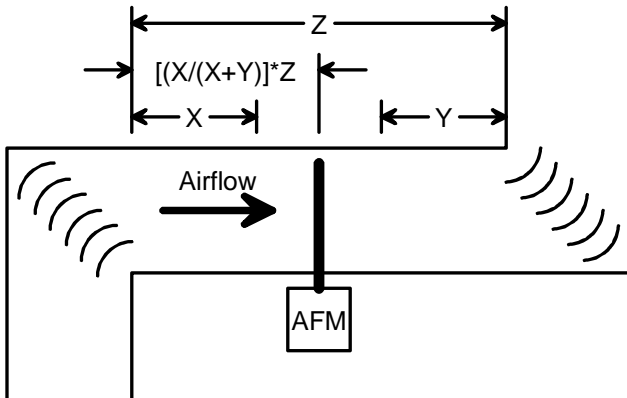

Figure 4. Standoff Mount Probe Spacing/Configuration

IG_GP1_HP1_SP1_SOM_R1C

DUCTED APPLICATIONS - MINIMUM PLACEMENT GUIDELINES



Formula indicates the optimum placement distance where:
 X= Minimum distance to upstream disturbance
 Y= Minimum distance to downstream disturbance
 Z= Total distance between upstream and downstream disturbances.

Typical GP1 Placement Example

CAUTIONS/WARNINGS

- ⚠ Contact **EBTRON** if minimum placement guidelines cannot be achieved.
- ⚠ If other devices are used to verify performance, make sure that measurements are taken at locations that meet the minimum placement and flow requirements of the verification device (pitot tubes require greater distances).
- ⚠ Avoid locating the airflow measurement station immediately downstream of a modulating or partially closed damper. Contact **EBTRON** for assistance if a modulating damper is upstream of the flow station, regardless of the distance.
- ⚠ Do not locate the airflow measurement station where it will be exposed to rain or condensate from a humidifier or coil. Consult humidifier or coil manufacturer for absorption distance recommendations.

MINIMUM PLACEMENT GUIDE ('D', 'C', 'B' and 'A' Sensor Density Probes)

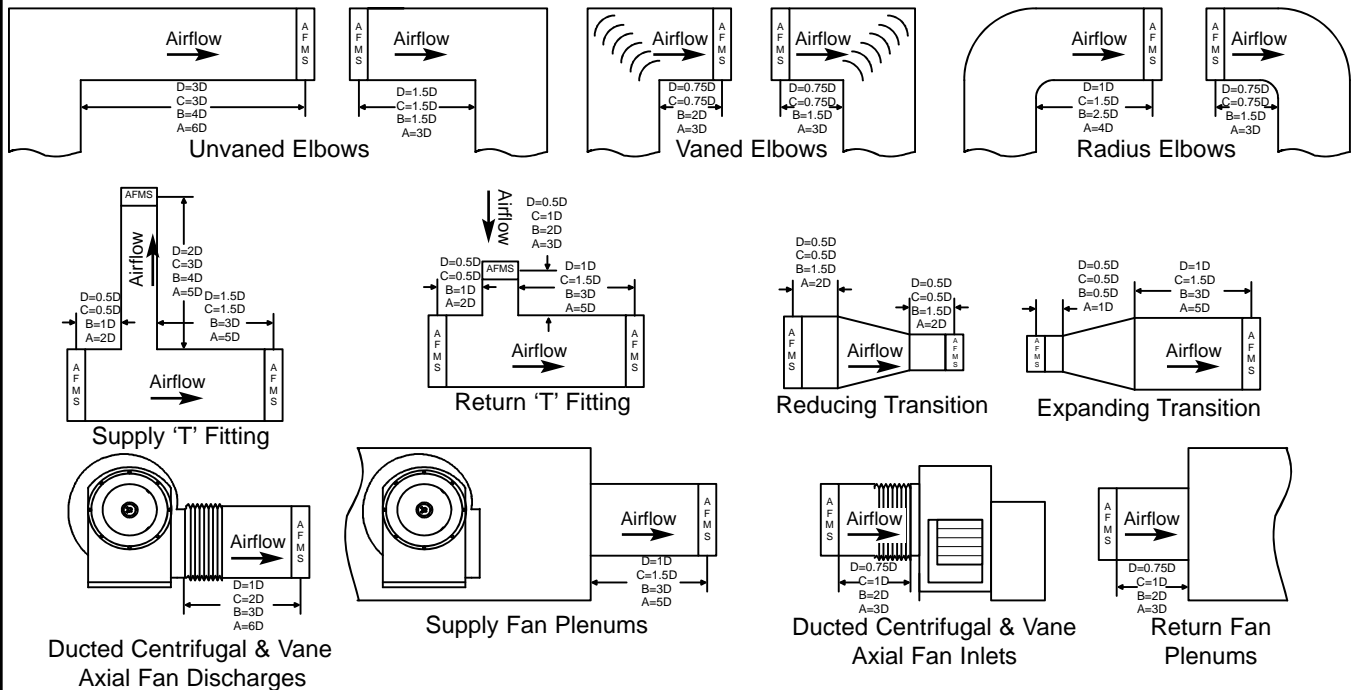

D = Simple Equivalent Diameter = (width + height)/2

Refer to Figure 6 for guidelines on placement in or near louvers or dampers.

Figure 5. GP1 Minimum Placement Guide

IG_GP1_HP1_SP1_SOM_R1C

**OUTSIDE AIR INTAKE DAMPER/PLENUM APPLICATION EXAMPLES SHOWING
MINIMUM DISTANCE REQUIREMENTS**

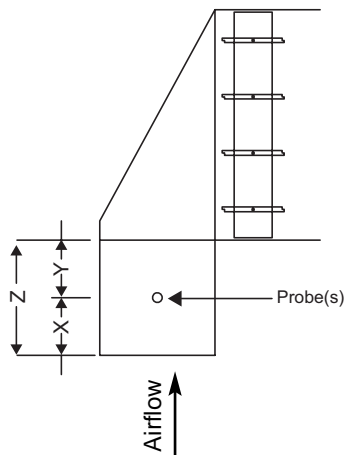

NOTES: X, Y = 6 in (152.4 mm) MINIMUM
Z = 12 in (304.8 mm) MINIMUM

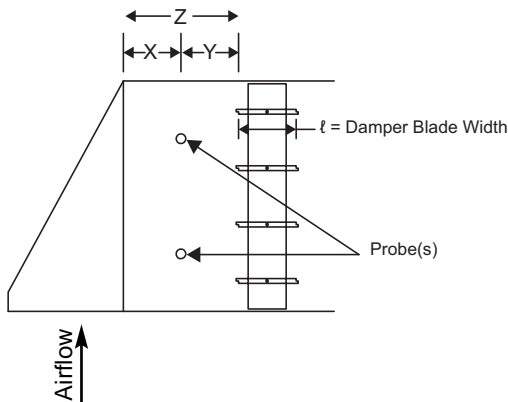
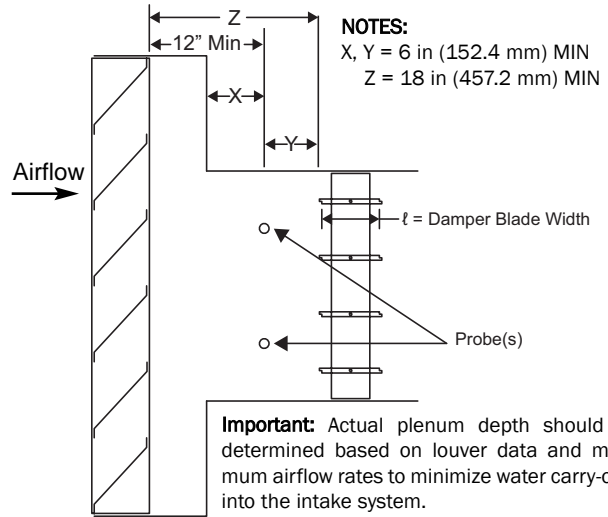

NOTES: X, Y = 6 in (152.4 mm) MINIMUM
Z = 12 in (304.8 mm) MINIMUM

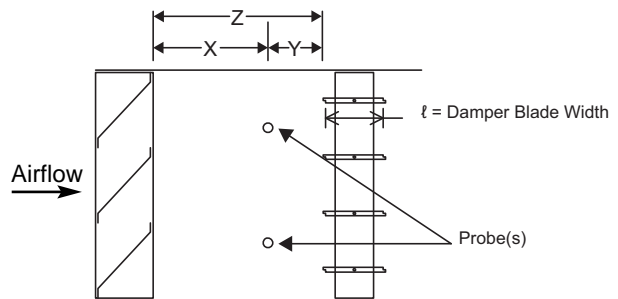

NOTES: X = 12 in (304.8 mm) MINIMUM
Y = 6 in (152.4 mm) MINIMUM
Z = 18 in (457.2 mm) MINIMUM

KEY:

- X = Distance to upstream disturbance
- Y = Distance to downstream disturbance
- Z = Distance between disturbances
- ℓ = Damper blade width

Consult your **EBTRON** Sales Rep for assistance with probe placement in critical Outside Air and Damper applications.

Figure 6. GP1 Outside Air Applications - Minimum Placement Guide

