

# Advantage

Gold Series by Ebtron

GOLD SERIES  
TECHNICAL MANUAL

*Installation, Operation and Maintenance Technical Manual*

## **GF1**

### **Adjustable Fan Inlet Sensors**

**For use with GTx116 Transmitters**

Including:

Combination Analog/RS-485 output model: GTC116-F

Includes Ethernet output model: GTE116-F

Includes LonWorks<sup>®</sup> output model: GTL116-F

Document Name: *TM\_GF1\_R2C*



TM\_GF1\_R2C

Typical Throat Mount, Face Mount and Forward Mount Applications - Single inlet fan installation shown for illustration only.

Part Number: 930-0045

EBTRON, Inc. 1663 Hwy. 701 S., Loris SC 29569 • Toll Free: 800.2EBTRON (232.8766) • Fax: 843.756.1838 • Internet: [EBTRON.com](http://EBTRON.com)

**LIST OF EFFECTIVE AND CHANGED PAGES**

Insert latest changed pages (in bold text); remove and dispose of superseded pages.  
Total number of pages in this manual is **12**.

Page No	Revision *	Description of Change	Date
<b>1, 2</b>	<b>R2C</b>	<b>Updated Title page and List of Effective pages to R2C</b>	<b>01/03/2012</b>
<b>1, 4</b>	<b>R2C</b>	<b>Removed references to GTN products</b>	<b>01/03/2012</b>
11	R2B	Updated maintenance note regarding filtering	10/17/2011
1 through 12	R2A	*Updated document to include Forward Mounting option	9/21/2010
3 through 7	R1G	No change from initial Document Release	11/25/2008
8	R1G	Added offset dimension on face mount rods	2/9/2009

\* Entire document reissued as revision R2A.

Copyright © 2009 EBTRON®, Inc.  
All brand names, trademarks and registered trademarks are the property of their respective owners. Information contained within this document is subject to change without notice. Visit [EBTRON.com](http://EBTRON.com) to view and/or download the most recent versions of this and other documents.  
All rights reserved.

**Table of Contents**

OVERVIEW .....4  
 SPECIFICATIONS .....4  
 ADVANCED TECHNOLOGY .....4  
 APPLICATIONS .....4  
 SELECTION OF MOUNTING STYLES .....5  
     Throat Mount Sensor Placement Guide .....5  
         Throat Mount for Centrifugal Fans .....5  
         Throat Mount for Vane Axial Fans .....5  
     Face Mount Sensor Placement Guide .....6  
         Plenum Fans - Face Mount .....6  
     Forward Mount Sensor Placement Guide .....6  
         Forward Mount .....6  
 INSTALLATION OF FAN INLET SENSORS .....7  
     Throat Mount Sensor Installation .....8  
     Face Mount Sensor Installation .....9  
     Forward Mount Sensor Installation .....10  
 MAINTENANCE .....11  
 STANDARD LIMITED PARTS WARRANTY .....11  
 MECHANICAL DIMENSIONS .....11

**List of Figures**

Figure 1. GF1 Fan Inlet Sensor Applications - Throat Mount, Face Mount and Forward Mount .....4  
 Figure 2. Centrifugal Fan Throat Mount .....5  
 Figure 3. Vane Axial Fan Throat Mount .....5  
 Figure 4. Plenum Fan Face Mount .....6  
 Figure 5. Forward Mount .....6  
 Figure 6. Throat Mount Detail (Left Sensor) .....8  
 Figure 7. Face Mount Sensor Detail .....9  
 Figure 8. Forward Mount Detail .....10  
 Figure 9. Throat Mount Sensor Detail Drawing .....11  
 Figure 10. Face Mount Sensor Detail Drawing .....11  
 Figure 11. Forward Mount Sensor Detail Drawing .....12

**List of Tables**

Table 1. Throat Mount Standard Sizes .....5  
 Table 2. Face Mount Standard Sizes .....6  
 Table 3. Forward Mount Standard Sizes .....6  
 Table 4. Throat Mount Dimension ‘L’ Determination .....8  
 Table 5. Face Mount Dimension “X” Determination .....9  
 Table 6. Forward Mount Dimension ‘X’ Determination .....10

## OVERVIEW

GF1 thermal dispersion fan inlet sensors (Figure 1) are designed for face or throat mounting in centrifugal, vane axial and plenum fans. A throat mount version is available for mounting directly in the inlet bell of centrifugal fans or upstream of the propeller in vane axial fans. A face mount and a new forward mount version are available for sensitive plenum fan applications. The streamline design of the sensor does not adversely affect fan performance like other, more cumbersome inlet sensors.

GF1 sensor probes use two “bead-in-glass” thermistors to determine the airflow rate and temperature at each sensing location. Accuracy is “percent of reading” (not “percent of full scale”). Performance is assured throughout the entire calibrated range. Probes are connected to an GTx116 transmitter that sums individual airflow and temperatures prior to averaging and outputs to the host control system.

GF1 probes are ideal for fan tracking applications, especially when duct configuration limits the use of -P duct and plenum probes.

## SPECIFICATIONS

### Sensor Probe Configurations

- Single inlet (probes x sensors/probe): 2x1 (independent sensors)
- Dual inlet (probes x sensors/probe): 4x1 (independent sensors)

### Sensor Accuracy

- Airflow:  $\pm 2\%$  of reading,  $\pm 0.25\%$  repeatability
- Temperature:  $\pm 0.15^\circ\text{F}$  ( $\pm 0.08^\circ\text{C}$ )

### Sensor Ranges

- Airflow: 0 to 10,000 fpm (0 to 50.8 m/s)
- Temperature:  $-20^\circ\text{F}$  to  $160^\circ\text{F}$  ( $-28.9^\circ\text{C}$  to  $71.1^\circ\text{C}$ )
- Humidity: 0 to 99% rh, non-condensing

### Sensor Assembly (each sensing point)

- Heated element: One bead-in-glass, hermetically sealed, thermistor probe
- Temperature sensor: One bead-in-glass, hermetically sealed, thermistor probe
- Sensor housing: Glass-filled polypropylene
- Sensor potting material: Marine grade, waterproof epoxy

### Standard Size Ranges

- 11 in. (279.4 mm) to 64 in. (1625.6 mm)

### Construction

- Sensor Mounting Block: 304 stainless steel
- Rod Construction: Adjustable length, cadmium plated rods
- Mounting Feet: 304 stainless steel

### Cable Assembly

- Type: UL® Plenum Rated, PVC jacket
- Length: 10 ft std. (3.048 m), 50 ft (15.24 m) max.
- Termination: 0.875 in. (22.2 mm) plug [transmitter end], gold plated pins

### “Plug and Play” Sensor Probes

- Probes do not require matching to transmitter

### Compatible Transmitters

- GTC116, GTE116 and GTL116

### Warranty

- 36 months from shipment

<sup>1</sup> Transmitter can be configured for outputs higher than calibrated range.



**Figure 1. GF1 Fan Inlet Sensor Applications - Throat Mount, Face Mount and Forward Mount**

## ADVANCED TECHNOLOGY

- **EBTRON** Advanced Thermal Dispersion (TD) airflow measurement technology ensures accurate, repeatable measurement from zero flow (still air).
- Each sensor is factory calibrated to **NIST traceable standards**.
- Mounts directly in the throat inlet of centrifugal or vane axial fans, and on the face of more sensitive plenum fans.
- True average independent, multi-point sensors.
- Highest quality and stability hermetically sealed “bead-in-glass” thermistors.
- Exclusive “Plug and Play” SMART sensor design with provision for up to 4 airflow sensors.
- Versatile mounting options for placement in the most challenging field locations.

## APPLICATIONS

- Volumetric airflow rate fan tracking.
- Building pressurization control.
- Monitoring air changes.
- Temperature and humidity control.

## SELECTION OF MOUNTING STYLES

GF1 sensors are available in traditional throat mount versions for centrifugal and vane axial fan applications, and in face mount or forward mount versions for more sensitive plenum fan applications. Six standard sizes are available in each mounting style.

GF1 sensor probes are designed for use in the GTx116 transmitters. Probes are available for either single or dual inlet fan installations. Single inlet applications are designated GTx116-F/SI, and dual inlet configurations are designated GTx116-F/DI. Each fan inlet uses two adjustable length sensor probes.

### Throat Mount Sensor Placement Guide

#### Throat Mount for Centrifugal Fans

Locate the sensor probes in the narrowest portion of the inlet cone as indicated in Figure 2 for the most reliable performance. Table 1 lists the standard Throat Mount sizes available.

#### Throat Mount for Vane Axial Fans

Locate the sensor probes upstream of the fan blades as illustrated in Figure 3. Refer to Table 1 for standard sizes.

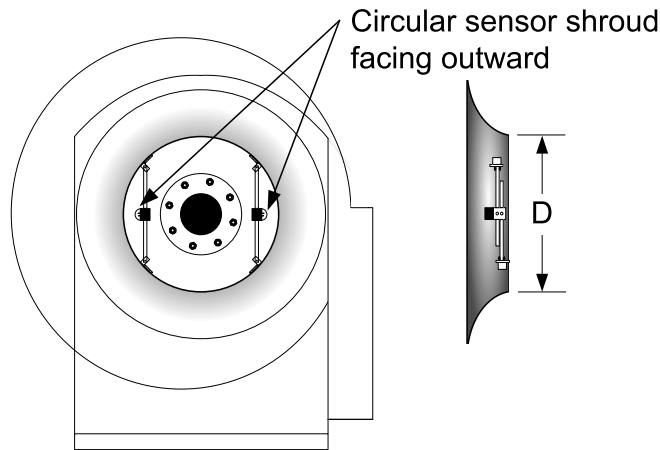

Figure 2. Centrifugal Fan Throat Mount

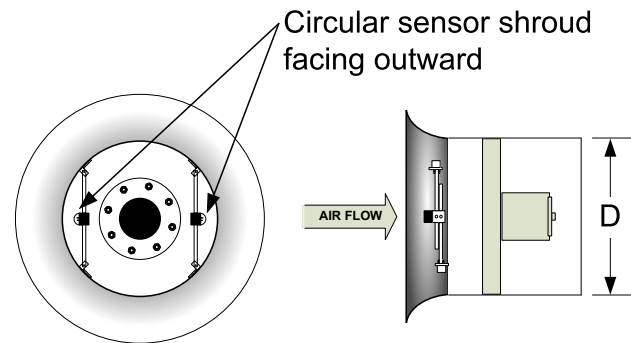

Figure 3. Vane Axial Fan Throat Mount

Table 1. Throat Mount Standard Sizes

Standard Size Code	Inlet Throat Diameter				Rod 4 Pack Part Number
	is greater than or equal to		and is less than		
	inches	mm	inches	mm	
1	11	279.40	14	355.60	700-3055
2	14	355.60	17	431.80	700-3056
3	17	431.80	29	736.60	700-3057
4	29	736.60	43	1092.20	700-3058
5	43	1092.20	57	1447.80	700-3059
6	57	1447.80	64	1625.60	700-3060

TM\_GF1\_R2A

**Face Mount Sensor Placement Guide**

**Plenum Fans - Face Mount**

Locate the sensor probes on the flat face portion of the inlet bell, as shown in Figure 4. Note that the inlet **FLAT FACE** diameter "D", is measured at the **flat portion of the flat face of the inlet at the point where the inlet flare just begins**. Table 2 lists the standard Face Mount sizes available.

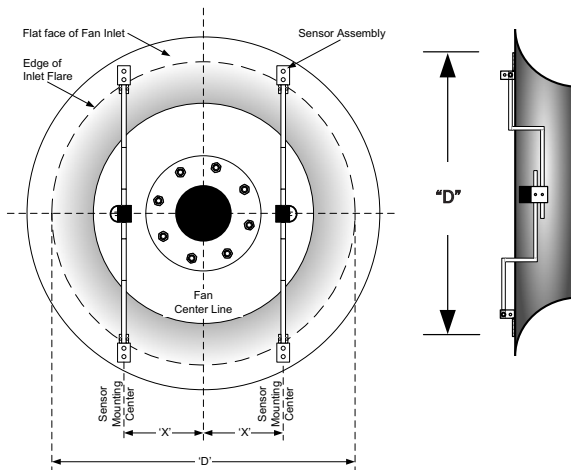

**Face Mount:**  
"D" is the diameter of the flat portion of the large inlet opening at the point where the inside flare begins.

Figure 4. Plenum Fan Face Mount

Table 2. Face Mount Standard Sizes

Standard Size Code	Inlet Face Diameter				Rod 4 Pack Part Number
	is greater than or equal to		and is less than		
	inches	mm	inches	mm	
1	11	279.40	13	330.20	700-4055
2	13	330.20	18	457.20	700-4056
3	18	457.20	23	584.20	700-4057
4	23	584.20	32	812.80	700-4058
5	32	812.80	46	1168.40	700-4059
6	46	1168.40	64	1625.60	700-4060

"D" Inlet Face Diameter - Measure Across **Flat Face at Flare Edge**

**Forward Mount Sensor Placement Guide**

**Forward Mount**

Locate the sensor probes on the flat face portion of the inlet bell, as shown in Figure 5. Note that the inlet **FLAT FACE** diameter "D", is measured at the **flat portion of the flat face of the inlet at the point where the inlet flare just begins**. Table 3 lists the standard Forward Mount sizes available.

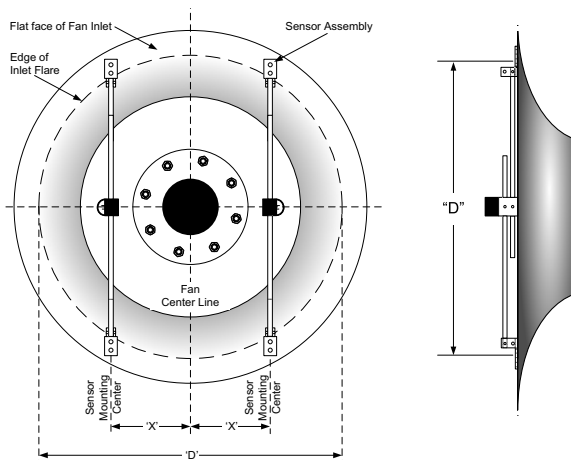

**Forward Mount:**  
"D" is the diameter of the flat portion of the large inlet opening at the point where the inside flare begins.

Figure 5. Forward Mount

Table 3. Forward Mount Standard Sizes

Standard Size Code	Inlet Face Diameter				Rod 4 Pack Part Number
	is greater than or equal to		and is less than		
	inches	mm	inches	mm	
1	11	279.40	13	330.20	700-5055
2	13	330.20	18	457.20	700-5056
3	18	457.20	23	584.20	700-5057
4	23	584.20	32	812.80	700-5058
5	32	812.80	46	1168.40	700-5059
6	46	1168.40	64	1625.60	700-5060

"D" Inlet Face Diameter - Measure Across **Flat Face at Flare Edge**







TM\_GF1\_R2A

## INSTALLATION OF FAN INLET SENSORS

The following paragraphs detail installation of each mounting style for fan inlet sensors. Measurement of the fan inlet diameter is critical to ensure optimum performance from the airflow measurement station.

Read and understand the Installation Precautions below and all installation steps prior to mounting the sensors.

### INSTALLATION PRECAUTIONS

-  Setting the specified rod length is essential for proper installation and sensor performance.
-  Failure to setup and/or properly secure the GF1 sensor assembly can result in sensor and/or fan damage.
-  Improper lubrication of the fan bearings can result in oil carry over and material buildup on the sensor.
-  The cable length ordered must be long enough to reach the transmitter from the furthest sensor probe.
-  Select suitable hardware for the installation and make sure that the screws will not interfere with rotation of the fan.
-  Avoid placement in the absorption area of humidifiers as this will adversely affect performance.

The sensors must always be installed in pairs (left and right) at the specified locations in the fan inlet and parallel to one another. When installed properly, sensor shrouds face outward as shown in the illustrations.

A left and right hand sensor are provided so that cable exits are downward to ensure that any potential condensate will flow away from the sensor body.

Check for obstructions in the fan inlet prior to installation. It may be necessary to rotate the orientation of the sensors in order to clear obstacles in the fan inlet.

For specific installation questions, concerns or assistance, please contact **EBTRON** Applications Engineering Team at 800.2EBTRON (800.232-8766).

**Throat Mount Sensor Installation**

1. Physically locate the fan indicated on the engineer's plans where the air flow measuring station is to be installed.
2. Measure the diameter ("D") of the inlet of the fan where the sensor assemblies will be installed as shown in Figures 2 and 3. Refer to Table 1 to verify that the proper sensors and rod 4 packs have been received.
3. Using sensor marked "INSIDE LEFT", insert a mounting rod into sensor mounting block inner rod hole with sensor oriented as in Figure 6 and cable exit downward.
4. Insert a second mounting rod from the opposite direction into the outermost hole as shown in Fig. 6.
5. Locate **DIMENSION 'L'** in Table 4 to determine the setup distance, "L", measured from roll pin to sensor set screws.
6. Adjust inner and outer rods so that the distance between the roll pin of each foot and the set screws on the mounting block are equal to "L".
7. Tighten the set screws using the hex wrench provided.
8. Repeat Steps 3 thru 7 to prepare an INNER RIGHT sensor with sensor shroud oriented to the right (opposite as shown in Figure 6) with cable exit downward.
9. Install the sensor assembly labeled "INSIDE LEFT" at left side of fan inlet with the sensor shroud pointing outward and cable exit downward. Select suitable hardware for the installation that will not hinder rotation of the fan.
10. Install the sensor assembly labeled "INSIDE RIGHT" at right side of fan inlet with the sensor shroud pointing outward and cable exit downward. Select suitable hardware for the installation that will not hinder rotation of the fan.
11. Strap down sensor cables to the mounting rods using the tie wraps provided (minimum two tie wraps per sensor).
12. Route sensor cables to the area where the transmitter will be located and secure the cables with appropriate hardware. Sensor installation is complete. Refer to the separate technical manual TM\_GTx116 for connection and set up of the GTx116 transmitter.
13. For dual fan inlet applications, repeat steps 3 through 12 to install sensors at the other fan inlet opening.

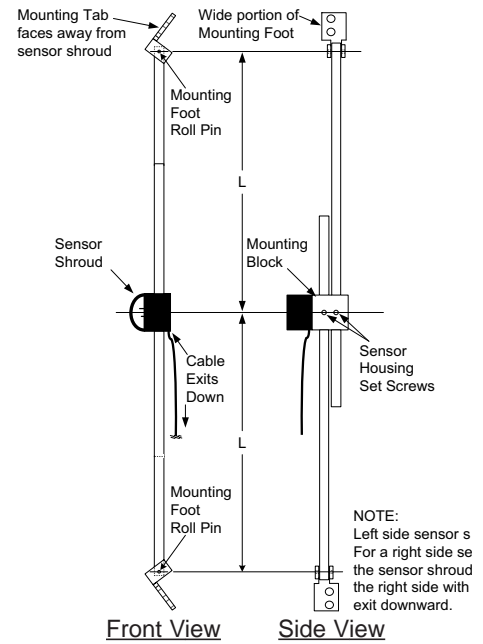
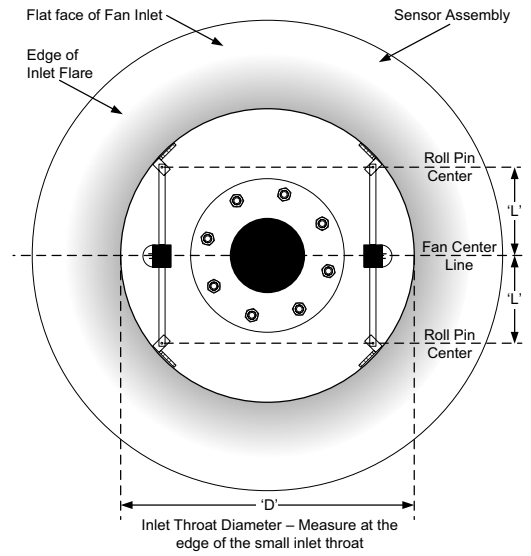

**Figure 6. Throat Mount Detail (Left Sensor)**

**Table 4. Throat Mount Dimension 'L' Determination**

Inlet Diameter "D" (in.)	L (in.)	Inlet Diameter "D" (mm)	L (mm)	Inlet Diameter "D" (in.)	L (in.)	Inlet Diameter "D" (mm)	L (mm)	Inlet Diameter "D" (in.)	L (in.)	Inlet Diameter "D" (mm)	L (mm)
11	3 11/16	279.40	93.84	29	11 1/4	736.60	286.25	47	18 7/8	1193.80	478.66
12	4 1/8	304.80	104.53	30	11 11/16	762.00	296.94	48	19 1/4	1219.20	489.35
13	4 9/16	330.20	115.22	31	12 1/8	787.40	307.63	49	19 11/16	1244.60	500.04
14	4 15/16	355.60	125.91	32	12 1/2	812.80	318.32	50	20 1/8	1270.00	510.73
15	5 3/8	381.00	136.59	33	12 15/16	838.20	329.01	51	20 1/2	1295.40	521.42
16	5 13/16	406.40	147.28	34	13 3/8	863.60	339.70	52	20 5/16	1320.80	532.11
17	6 1/4	431.80	157.97	35	13 13/16	889.00	350.39	53	21 3/8	1346.20	542.80
18	6 5/8	457.20	168.66	36	14 3/16	914.40	361.08	54	21 13/16	1371.60	553.49
19	7 1/16	482.60	179.35	37	14 5/8	939.80	371.77	55	22 3/16	1397.00	564.18
20	7 1/2	508.00	190.04	38	15 1/16	965.20	382.46	56	22 5/8	1422.40	574.87
21	7 7/8	533.40	200.73	39	15 1/2	990.60	393.15	57	23 1/16	1447.80	585.56
22	8 5/16	558.80	211.42	40	15 7/8	1016.00	403.83	58	23 8/16	1473.20	596.25
23	8 3/4	584.20	222.11	41	16 5/16	1041.40	414.52	59	23 7/8	1498.60	606.94
24	9 3/16	609.60	232.80	42	16 3/4	1066.80	425.21	60	24 5/16	1524.00	617.63
25	9 9/16	635.00	243.49	43	17 3/16	1092.20	435.90	61	24 3/4	1549.40	628.32
26	10	660.40	254.18	44	17 9/16	1117.60	446.59	62	25 3/16	1574.80	639.01
27	10 7/16	685.80	264.87	45	18	1143.00	457.28	63	25 9/16	1600.20	649.70
28	10 7/8	711.20	275.56	46	18 7/16	1168.40	467.97	64	26	1625.60	660.38

L = distance between locking set screw at sensor housing and mounting foot roll pin

TM\_GF1\_R2A

**Face Mount Sensor Installation**

1. Physically locate the fan where the air flow measuring station is to be installed on the engineer's plans.
2. Use the hex wrench provided to loosen the sensor housing set screws on the sensor mounting block as shown in Figure 7.
3. Using sensor marked "INSIDE LEFT", insert an inner mounting rod (with mounting bracket attached at inner roll pin) into sensor mounting block inner rod hole with sensor oriented as in Fig. 7.
4. Insert outer mounting rod (with mounting bracket attached at outer roll pin) into sensor mounting block outer rod hole (Figure 7).
5. Using sensor marked "INSIDE RIGHT", repeat steps 3 and 4 with sensor shroud oriented to the right (opposite) as in Figure 7.
7. Measure the diameter ('D') of the fan inlet **FLAT FACE**, measured at the **flat portion of the flat face of the inlet at the point where the inlet flare just begins**.
8. Using Diameter 'D', locate DIMENSION 'X' in Table 5 to determine the fan inlet center line to sensor mounting center line for each sensor as shown in Figure 7.
9. Adjust the inner and outer rods of each sensor so that the distance between the left and right rod centers and the fan center line is equal to dimension 'X'. Now adjust the mounting block so that the sensor body is located exactly at the horizontal fan center line. Tighten the set screws using the hex wrench provided.
10. Install sensor assembly labeled "INSIDE LEFT" at the left side of the flat face of the fan inlet as in Figure 7. Use suitable hardware for installation that does not hinder rotation of the fan.
11. Install sensor assembly labeled "INSIDE RIGHT" at the right side of the flat face of the fan inlet as in Figure 7. Use suitable hardware for installation that does not hinder rotation of the fan.
12. Strap down sensor cables to mounting rods using the tie wraps provided (minimum of two tie wraps per sensor).
13. Route sensor cables to the transmitter and secure them with appropriate hardware. Sensor installation is complete. Refer to the separate technical manual TM\_GTx116 for connection and set up of the GTx116 transmitter.
14. For dual fan inlet applications, repeat steps 3 through 13 to install sensors at the other fan inlet opening.

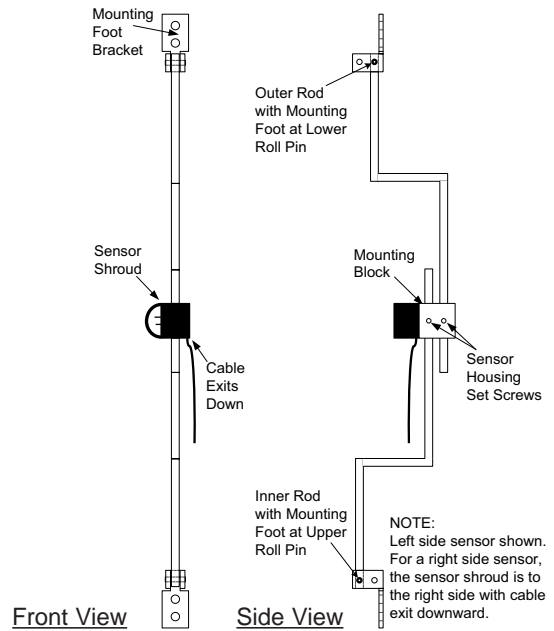
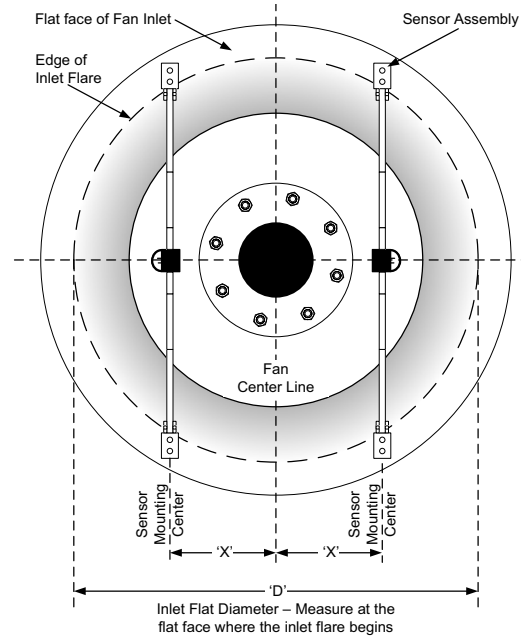

Figure 7. Face Mount Sensor Detail

Table 5. Face Mount Dimension "X" Determination

Inlet Diameter "D" (in.)	X (in.)	Inlet Diameter "D" (mm)	X (mm)	Inlet Diameter "D" (in.)	X (in.)	Inlet Diameter "D" (mm)	X (mm)	Inlet Diameter "D" (in.)	X (in.)	Inlet Diameter "D" (mm)	X (mm)
11	3 3/8	279.40	86.08	29	9 3/4	736.60	247.73	47	16 1/8	1193.80	409.37
12	3 3/4	304.80	95.06	30	10 1/8	762.00	256.71	48	16 1/2	1219.20	418.35
13	4 1/8	330.20	104.04	31	10 7/16	787.40	265.69	49	16 13/16	1244.60	427.33
14	4 7/16	355.60	113.02	32	10 13/16	812.80	274.67	50	17 3/16	1270.00	436.31
15	4 13/16	381.00	122.00	33	11 3/16	838.20	283.65	51	17 1/2	1295.40	445.29
16	5 3/16	406.40	130.98	34	11 1/2	863.60	292.63	52	17 7/8	1320.80	454.27
17	5 1/2	431.80	139.96	35	11 7/8	889.00	301.61	53	18 1/4	1346.20	463.25
18	5 7/8	457.20	148.94	36	12 1/4	914.40	310.59	54	18 9/16	1371.60	472.23
19	6 3/16	482.60	157.92	37	12 9/16	939.80	319.57	55	18 15/16	1397.00	481.21
20	6 9/16	508.00	166.91	38	12 15/16	965.20	328.55	56	19 5/16	1422.40	490.19
21	6 15/16	533.40	175.89	39	13 5/16	990.60	337.53	57	19 5/8	1447.80	499.17
22	7 1/4	558.80	184.87	40	13 5/8	1016.00	346.51	58	20	1473.20	508.15
23	7 5/8	584.20	193.85	41	14	1041.40	355.49	59	20 3/8	1498.60	517.14
24	8	609.60	202.83	42	14 3/8	1066.80	364.47	60	20 11/16	1524.00	526.12
25	8 5/16	635.00	211.81	43	14 11/16	1092.20	373.45	61	21 1/16	1549.40	535.10
26	8 11/16	660.40	220.79	44	15 1/16	1117.60	382.43	62	21 7/16	1574.80	544.08
27	9 1/16	685.80	229.77	45	15 7/16	1143.00	391.41	63	21 3/4	1600.20	553.06
28	9 3/8	711.20	238.75	46	15 3/4	1168.40	400.39	64	22 1/8	1625.60	562.04

Refer to detail in Figure 7 for "D" Inlet Diameter and "X" distance between fan center line and sensor center line.

**Forward Mount Sensor Installation**

1. Physically locate the fan where the air flow measuring station is to be installed on the engineer's plans.
2. Use the hex wrench provided to loosen the sensor housing set screws on the sensor mounting block as shown in Figure 8.
3. Using sensor marked "INSIDE LEFT", insert an inner mounting rod (with mounting bracket attached at inner roll pin) into sensor mounting block inner rod hole with sensor oriented as in Fig. 8.
4. Insert outer mounting rod (with mounting bracket attached at outer roll pin) into sensor mounting block outer rod hole (Figure 8).
5. Using sensor marked "INSIDE RIGHT", repeat steps 3 and 4 with sensor shroud oriented to the right (opposite) as in Figure 8.
7. Measure the diameter ('D') of the fan inlet **FLAT FACE**, measured at the flat portion of the flat face of the inlet at the point where the inlet flare just begins.
8. Using Diameter 'D', locate DIMENSION 'X' in Table 6 to determine the fan inlet center to sensor center line for each sensor as shown in Figure 8.
9. Adjust the inner and outer rods of each sensor so that the distance between the left and right rod centers and the fan center line is equal to dimension 'X'. Now adjust the mounting block so that the sensor body is located exactly at the horizontal fan center line. Tighten the set screws using the hex wrench provided.
10. Install sensor assembly labeled "INSIDE LEFT" at the left side of the flat face of the fan inlet as in Figure 8. Use suitable hardware for installation that does not hinder rotation of the fan.
11. Install sensor assembly labeled "INSIDE RIGHT" at the right side of the flat face of the fan inlet as in Figure 8. Use suitable hardware for installation that does not hinder rotation of the fan.
12. Strap down sensor cables to mounting rods using the tie wraps provided (minimum of two tie wraps per sensor).
13. Route sensor cables to the transmitter and secure them with appropriate hardware. Sensor installation is complete. Refer to the separate technical manual TM\_GTx116 for connection and set up of the GTx116 transmitter.
14. For dual fan inlet applications, repeat steps 3 through 13 to install sensors at the other fan inlet opening.

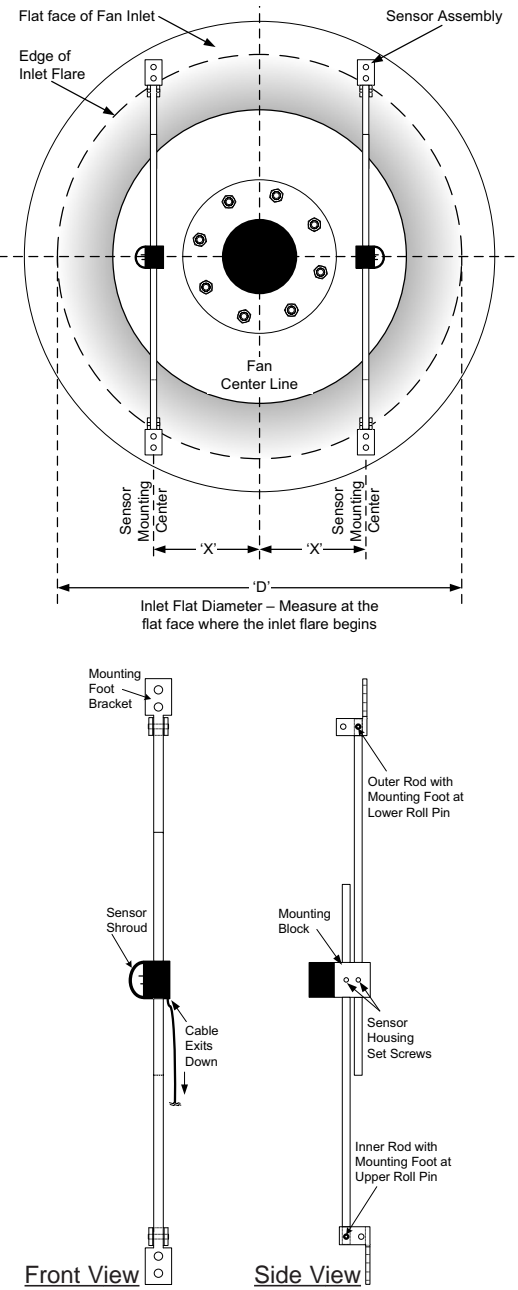

Figure 8. Forward Mount Detail

Table 6. Forward Mount Dimension 'X' Determination

Inlet Diameter 'D' (in.)	'X' (in.)	Inlet Diameter 'D' (mm)	'X' (mm)	Inlet Diameter 'D' (in.)	'X' (in.)	Inlet Diameter 'D' (mm)	'X' (mm)	Inlet Diameter 'D' (in.)	'X' (in.)	Inlet Diameter 'D' (mm)	'X' (mm)
11	3 3/8	279.40	86.08	29	9 3/4	736.60	247.73	47	16 1/8	1193.80	409.37
12	3 3/4	304.80	95.06	30	10 1/8	762.00	256.71	48	16 1/2	1219.20	418.35
13	4 1/8	330.20	104.04	31	10 7/16	787.40	265.69	49	16 13/16	1244.60	427.33
14	4 7/16	355.60	113.02	32	10 13/16	812.80	274.67	50	17 3/16	1270.00	436.31
15	4 13/16	381.00	122.00	33	11 3/16	838.20	283.65	51	17 1/2	1295.40	445.29
16	5 3/16	406.40	130.98	34	11 1/2	863.60	292.63	52	17 7/8	1320.80	454.27
17	5 1/2	431.80	139.96	35	11 7/8	889.00	301.61	53	18 1/4	1346.20	463.25
18	5 7/8	457.20	148.94	36	12 1/4	914.40	310.59	54	18 9/16	1371.60	472.23
19	6 3/16	482.60	157.92	37	12 9/16	939.80	319.57	55	18 15/16	1397.00	481.21
20	6 9/16	508.00	166.91	38	12 15/16	965.20	328.55	56	19 5/16	1422.40	490.19
21	6 15/16	533.40	175.89	39	13 5/16	990.60	337.53	57	19 5/8	1447.80	499.17
22	7 1/4	558.80	184.87	40	13 5/8	1016.00	346.51	58	20	1473.20	508.15
23	7 5/8	584.20	193.85	41	14	1041.40	355.49	59	20 3/8	1498.60	517.14
24	8	609.60	202.83	42	14 3/8	1066.80	364.47	60	20 11/16	1524.00	526.12
25	8 5/16	635.00	211.81	43	14 11/16	1092.20	373.45	61	21 1/16	1549.40	535.10
26	8 11/16	660.40	220.79	44	15 1/16	1117.60	382.43	62	21 7/16	1574.80	544.08
27	9 1/16	685.80	229.77	45	15 7/16	1143.00	391.41	63	21 3/4	1600.20	553.06
28	9 3/8	711.20	238.75	46	15 3/4	1168.40	400.39	64	22 1/8	1625.60	562.04

Refer to detail in Figure 8 for "D" Inlet Diameter and "X" distance between fan center line and sensor center line.

## MAINTENANCE

In most HVAC environments, periodic maintenance and calibration is neither required or recommended<sup>1</sup>.

<sup>1</sup>In certain applications where a large amount of airborne particulate is present, especially fibrous material such as lint, pre-filtering of the return air may be required to ensure optimum instrument performance. If no pre-filtering is provided, it may be necessary to periodically inspect and clean sensors using compressed air or a small brush. Factory performance returns immediately after cleaning. Recalibration is NOT required. Periodic inspection of the sensors is always advised, and accessibility must be considered in these applications.

## STANDARD LIMITED PARTS WARRANTY

If any **EBTRON** product fails within 36 months from shipment, **EBTRON** will repair/replace the device free of charge as described in the company's warranty contained in **EBTRON's TERMS AND CONDITIONS OF SALE**. Defective equipment shall be shipped back to **EBTRON**, freight pre-paid, for analysis.

## MECHANICAL DIMENSIONS

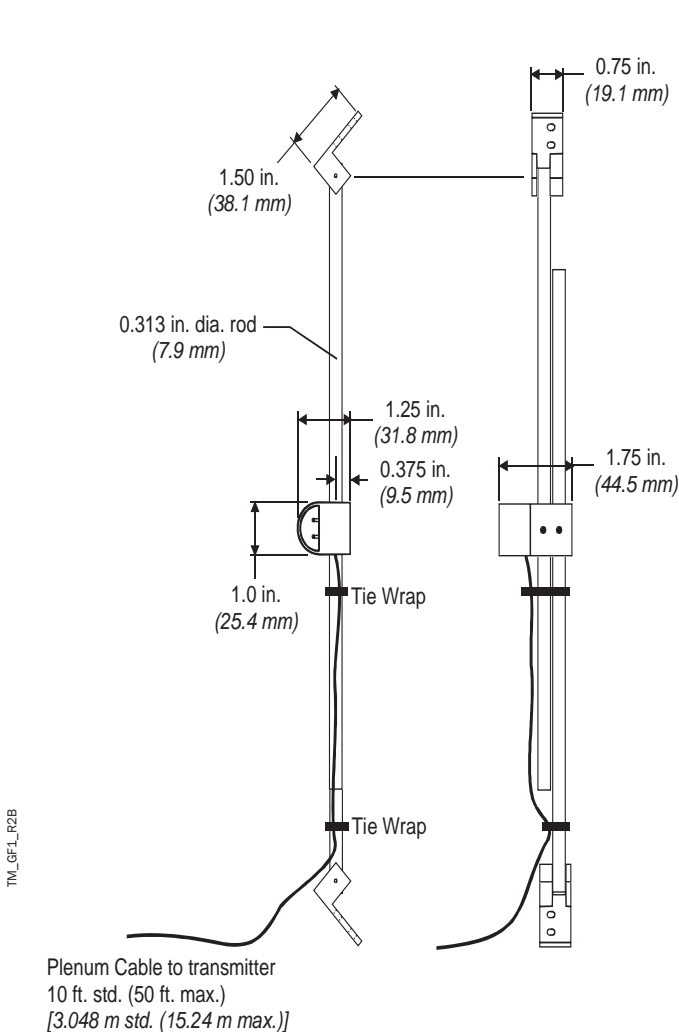

Figure 9. Throat Mount Sensor Detail Drawing

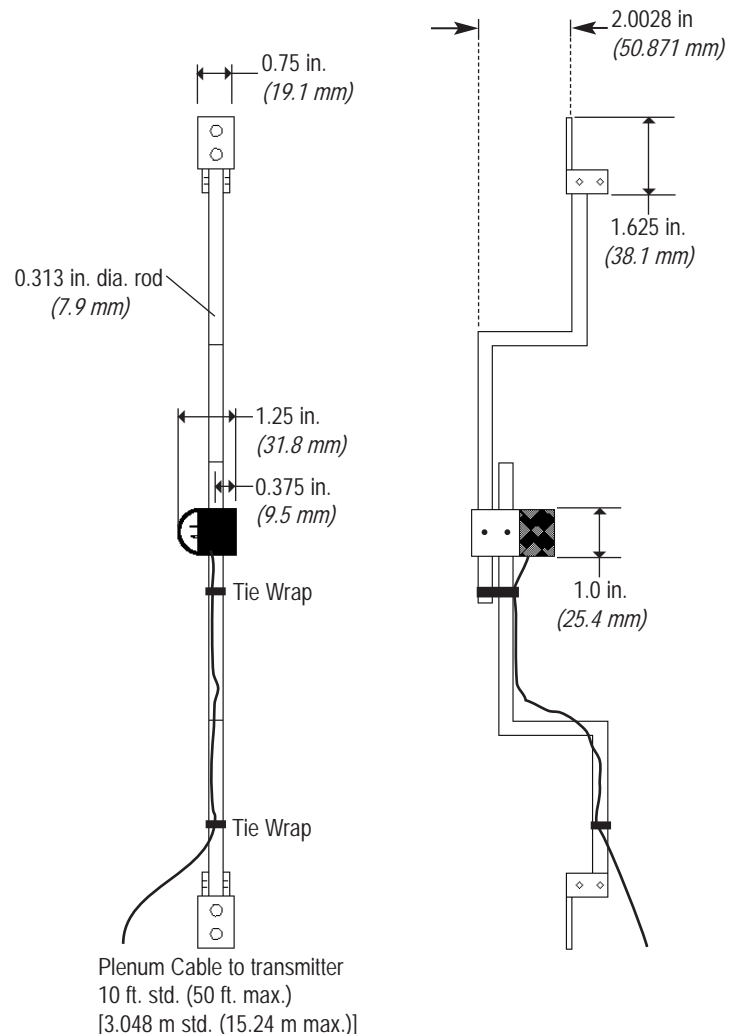

Figure 10. Face Mount Sensor Detail Drawing

TM\_GF1\_R2B

**MECHANICAL DIMENSIONS** (continued)

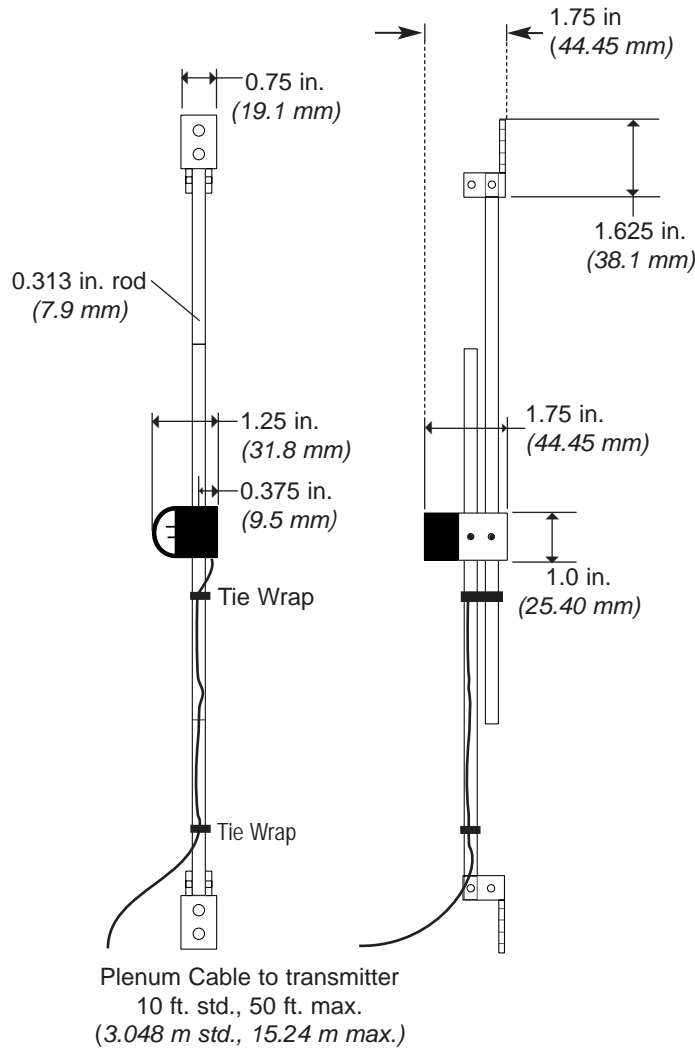

Figure 11. Forward Mount Sensor Detail Drawing

TM\_GF1\_R2A