

GOLD SERIES TECHNOLOGY OVERVIEW

The GTX116 transmitter can process up to 16 individual sensing nodes and requires 24 VAC to provide airflow and temperature measurement outputs. Models are available for concurrent analog and RS-485 (GTC116), RS-485 only (GTN116 with BACnet ARCNET), ethernet (GTE116) and LonWorks (GTL116) output for BAS networks. The transmitter is independent of the sensor probes thus eliminating field matching. The transmitter includes a 16 character LCD display that indicates airflow, temperature and system status, and is also useful during configuration and diagnostic modes. Field configuration and diagnostics are accomplished through a simple push-button interface on the main circuit board for selection of units of measure, display units, output scaling, dampening filter, diagnostics and instrument status. Individual sensor airflow and temperature measurements can be displayed and are beneficial as an HVAC system diagnostic tool.

A built in Field Calibration Wizard permits 1 or 2 point adjustment to factory calibration if required in less than optimum

placement applications. The airflow output signal can be filtered and a process low limit can be set to force the transmitter output to zero when airflow falls below a user defined value. Both features are important for outside air intake applications that can be affected by transient wind gusts at low airflow rates. In addition, an airflow offset and a gain adjustment feature can be engaged for installations where field calibration or adjustment is necessary.

A versatile programmable Alarm feature permits setting an airflow alarm output for Low Limit, High Limit, Setpoint with hysteresis, or can be set to activate in the event of a transmitter or sensor probe fault. **EBTRON's** GP1 sensor probes with proprietary flow loss compensation design are available in gold anodized aluminum (standard) or stainless steel (optional) finishes. Internal and Insertion duct mounting options are available, as well as an adjustable standoff mount for a wide range of damper applications.

PROBE MOUNTING STYLES AND BRACKET DIMENSIONS

INSERTION MOUNT BRACKET DETAIL

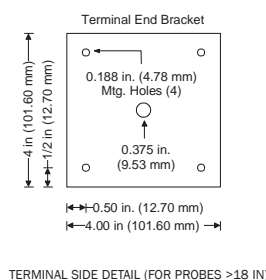
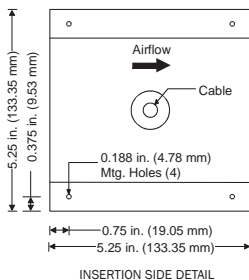
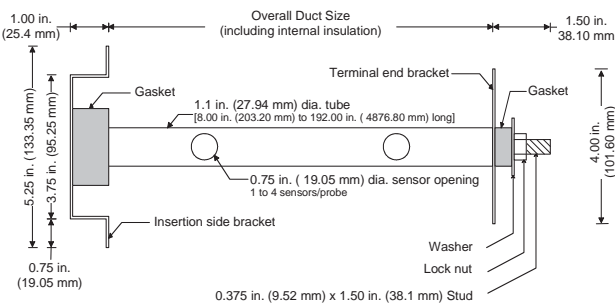

INTERNAL MOUNT BRACKET DETAIL

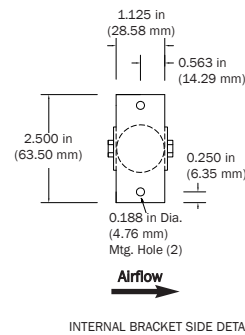
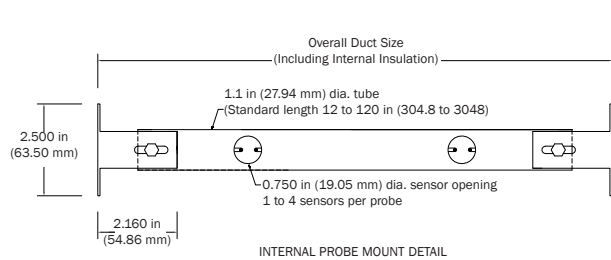

STANDOFF MOUNT DETAIL

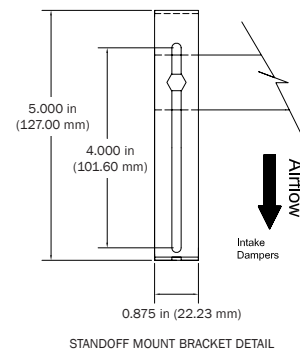
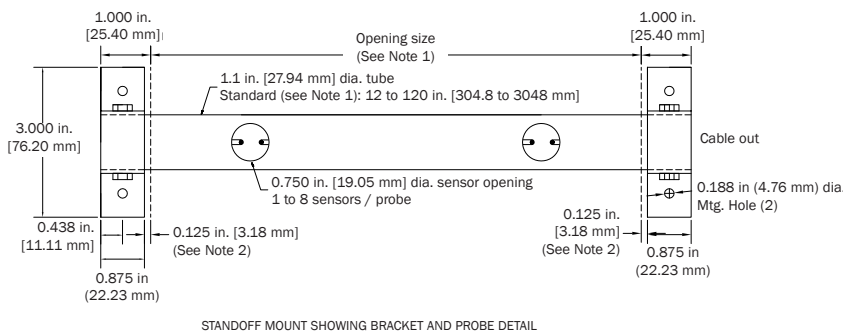

NOTES:

- Standoff probes are ordered by specifying the opening size. The probes supplied include an additional 2 in. [50.8 mm] of tube length (which is 2 in. longer than the specified opening size) to allow for bracket installation and damper blade clearance.
- 0.125 in. [3.175 mm] clearance (dashed line adjacent to each bracket) provided to ensure damper blade/linkage clearance.

'D' SENSOR DENSITY TABLES

EBTRON 'D' sensor density is our highest sensor density, developed for applications that do not meet the minimum placement requirements of the 'C' sensor density, for test laboratories, continuous commissioning and other applications where over-sampling of sensing points is desired or required. The 'D' sensor density is generally not required for most HVAC control applications. To maximize installed performance and accuracy, always follow minimum placement guidelines. The following tables indicate the quantity of probes and number of sensing nodes per probe provided for common rectangular and round/round-oval applications with probes from 12 to 120 inches.

GP1 'D' Sensor Density Tables

Rectangular Probe Sensor Density (# Probes / # Sensors per Probe)

GTx116-PD

		PROBE LENGTH - RECTANGULAR DUCTS														
		12	18	24	30	36	42	48	54	60	66	72	84	96	108	120
ADJACENT SIDE LENGTH	12	2/2	2/2	2/3	2/3	1/6	1/6	1/8	1/8	1/8	1/8	1/8	1/8	2/6	2/6	2/6
	18	2/2	2/3	2/3	2/3	2/4	2/4	2/4	2/4	2/4	2/6	2/6	2/6	2/8	2/8	2/8
	24	3/2	3/2	3/3	3/3	2/4	2/4	2/6	2/6	2/6	2/6	2/8	2/8	2/8	2/8	2/8
	30	4/2	3/2	3/3	3/3	3/3	3/4	3/4	3/4	4/4	4/4	4/4	2/8	2/8	2/8	2/8
	36	4/2	4/2	3/3	3/3	3/4	3/4	4/4	4/4	4/4	4/4	4/4	4/4	2/8	2/8	2/8
	42	4/2	4/2	4/2	4/3	4/3	4/4	4/4	4/4	4/4	4/4	4/4	4/4	4/4	2/8	2/8
	48	4/2	4/2	4/3	4/3	4/4	4/4	4/4	4/4	4/4	4/4	4/4	4/4	4/4	4/4	4/4
	54	4/2	4/2	4/3	4/3	4/4	4/4	4/4	4/4	4/4	4/4	4/4	4/4	4/4	4/4	4/4
	60	4/2	4/2	4/3	4/4	4/4	4/4	4/4	4/4	4/4	4/4	4/4	4/4	4/4	4/4	4/4
	66	4/2	4/3	4/3	4/4	4/4	4/4	4/4	4/4	4/4	4/4	4/4	4/4	4/4	4/4	4/4
	72	4/2	4/3	4/4	4/4	4/4	4/4	4/4	4/4	4/4	4/4	4/4	4/4	4/4	4/4	4/4
	84	4/2	4/3	4/4	4/4	4/4	4/4	4/4	4/4	4/4	4/4	4/4	4/4	4/4	4/4	4/4
	96	4/3	4/3	4/4	4/4	4/4	4/4	4/4	4/4	4/4	4/4	4/4	4/4	4/4	4/4	4/4
	108	4/3	4/3	4/4	4/4	4/4	4/4	4/4	4/4	4/4	4/4	4/4	4/4	4/4	4/4	4/4
	120	4/3	4/3	4/4	4/4	4/4	4/4	4/4	4/4	4/4	4/4	4/4	4/4	4/4	4/4	4/4
	144	4/3	4/3	4/4	4/4	4/4	4/4	4/4	4/4	4/4	4/4	4/4	4/4	4/4	4/4	4/4
	168	4/3	4/3	4/4	4/4	4/4	4/4	4/4	4/4	4/4	4/4	4/4	4/4	4/4	4/4	4/4
	192	4/3	4/3	4/4	4/4	4/4	4/4	4/4	4/4	4/4	4/4	4/4	4/4	4/4	4/4	4/4

Round-Oval Probe Sensor Density (# Probes / # Sensors per Probe)

GTx116-PD

		PROBE LENGTH - ROUND-OVAL DUCTS														
		12	18	24	30	36	42	48	54	60	66	72	84	96	108	120
ADJACENT SIDE LENGTH	12	2b/2	1a/4	1a/4	2b/2	2c/3	2c/3	2c/3	3c/3	3c/3	3c/3	3c/3	3c/3	3c/3	4c/3	4c/3
	18		2b/2	2b/2	2b/2	2b/2	2b/2	2c/3	2c/3	2c/3	2c/3	3c/3	3c/3	4c/3	4c/3	4c/3
	24			2b/4	2b/4	2b/4	2b/4	2b/4	2b/4	2b/4	2b/4	2b/4	2b/4	2b/4	2b/4	4c/4
	30				2b/4	2b/4	2b/4	2b/4	2b/4	2b/4	2b/4	2b/4	2b/4	2b/4	2b/4	2b/4
	36					3b/4	2b/6	2b/6	2b/6	2b/6	2b/6	2b/6	2b/6	2b/6	2b/6	2b/6
	42						2b/6	2b/6	2b/8	2b/8	2b/8	2b/8	2b/8	2b/8	2b/8	2b/8
	48							4b/4	2b/8	2b/8	2b/8	2b/8	2b/8	2b/8	2b/8	2b/8
	54								4b/4	2b/8	2b/8	2b/8	2b/8	2b/8	2b/8	2b/8
	60									4b/4	2b/8	2b/8	2b/8	2b/8	2b/8	2b/8
	66										4b/4	2b/8	2b/8	2b/8	2b/8	2b/8
	72											4b/4	2b/8	2b/8	2b/8	2b/8
	84												4b/4	2b/8	2b/8	2b/8
	96													4b/4	2b/8	2b/8
	108														4b/4	2b/8
	120															4b/4

'D' SENSOR DENSITY PLACEMENT GUIDELINES

Duct and Plenum Probe Minimum Placement Guidelines ('D' Density Probes)

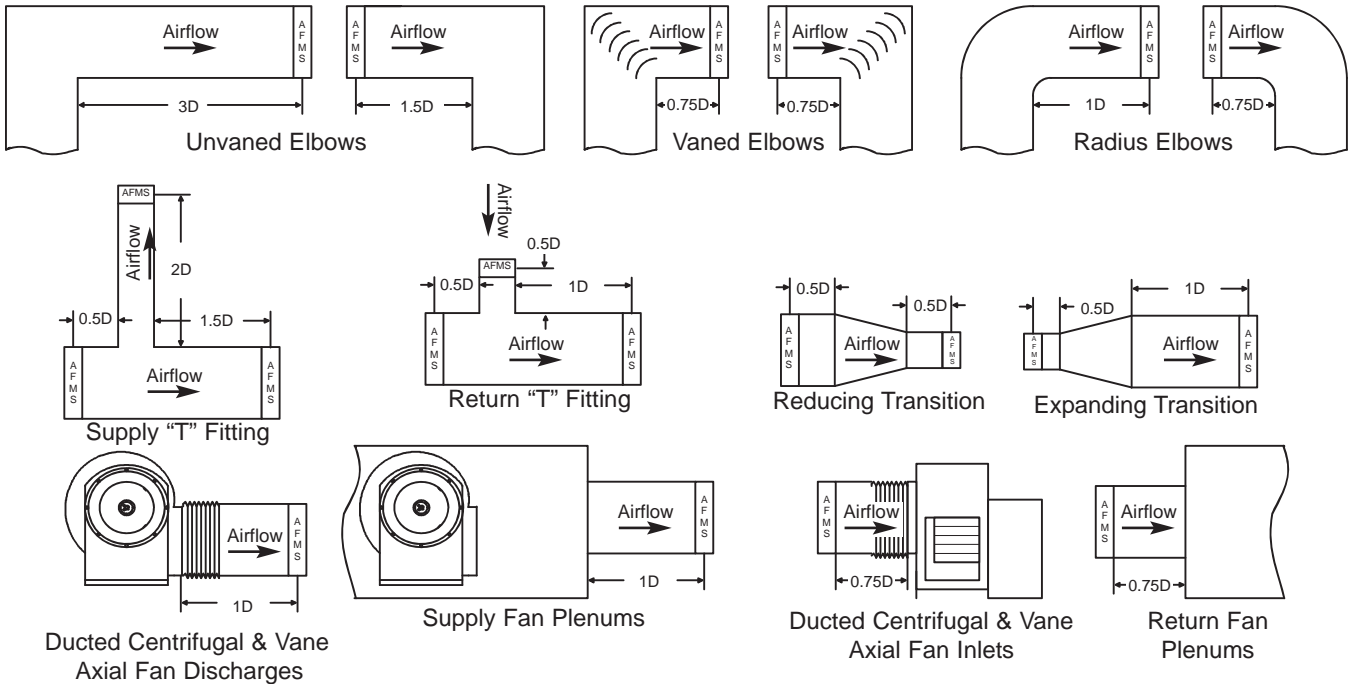

D = Simple Equivalent Diameter = (width + height)/2

Outside Air Intake Damper/Plenum Applications

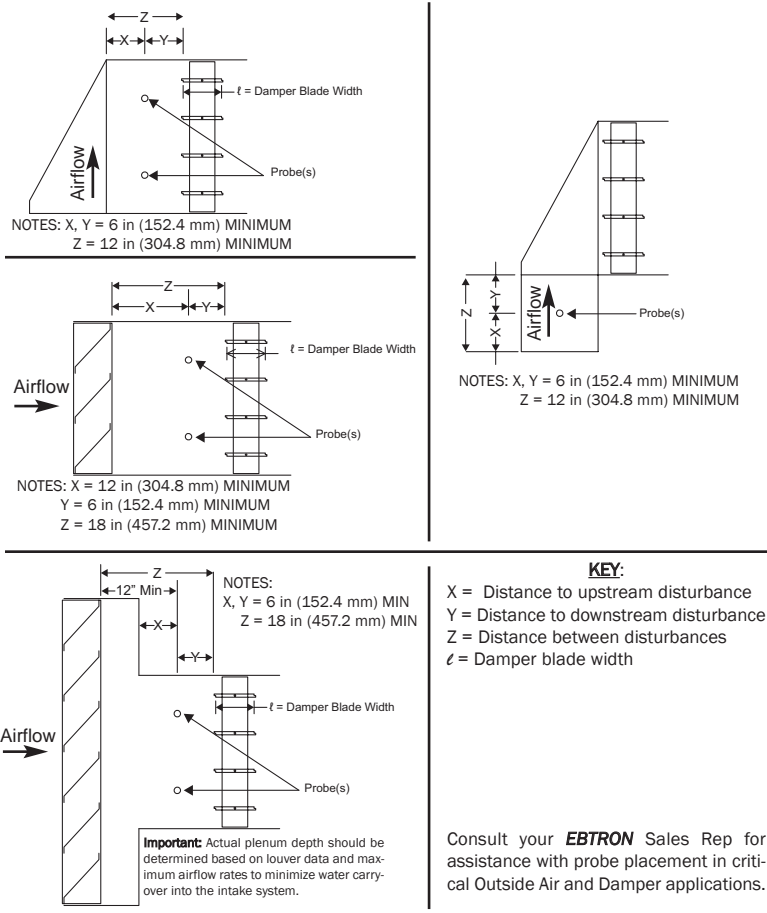

TYPICAL WIRING DIAGRAM

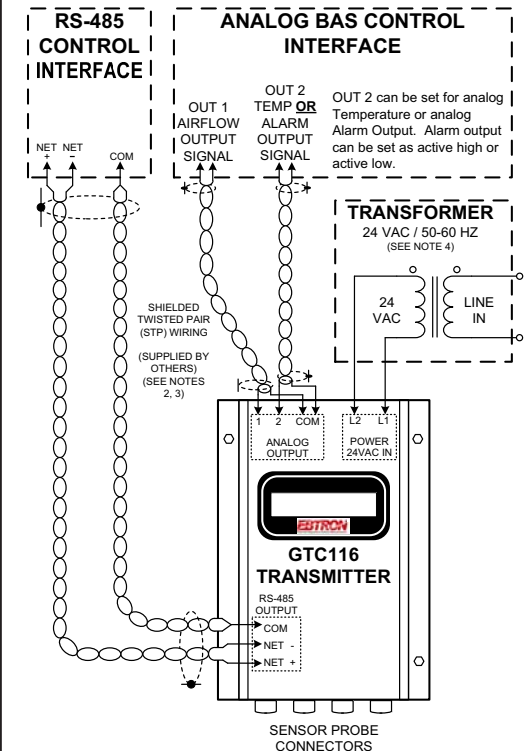

- NOTES:**
- OUTPUT 2 CAN BE SET AS TEMPERATURE OR AS AN ALARM. ALARM CAN BE SET AS ACTIVE HIGH OR ACTIVE LOW.
 - CONNECT OUTPUT SIGNAL CABLE DRAINS TO EARTH GROUND AT ONE END OF EACH CABLE ONLY.
 - RS-485 COM CONNECTION MAY USE A SINGLE CONDUCTOR.
 - ON MULTIPLE TRANSMITTER INSTALLATIONS WITH A COMMON 24VAC SOURCE, WIRE 24 VAC POWER IN-PHASE TO THE SAME TERMINALS ON ALL TRANSMITTERS (e.g.: L1 to L1, L2 to L2).

TS_GTC116PD_R1D